

Part V GENERAL HEALTH AND SAFETY REQUIREMENTS

Index

Section	Title	Revision Date
E27	<u>Travel over and work on ice</u>	September 2009
E29	<u>Roof Work</u>	September 2009
E38	<u>Emergency Plan Risk Assessment</u>	September 2009
E39	<u>Emergency Procedures</u>	September 2009
E41	<u>Emergency Training</u>	September 2009

Explanations

Section E27 Travel over and work on ice

Traveling over or working on ice carries some inherent risks. Be sure to measure clear hard ice in several places. It is the responsibility of the employer to identify the water depth at any given location where workers may be traveling or working. It is in the best interest of the employer to record these depths and ice thicknesses for comparison throughout the intended period of work.

Recommended minimum ice thicknesses are as follows:

- 3" (7.5 cm) or less - STAY OFF,
- 4" (10 cm) - ice fishing, walking, cross country skiing,
- 5" (12.5 cm) - one vehicle - snowmobile or ATV,
- 8-12" (20-30 cm) - one vehicle - car or small pick-up, and
- 12-15" (30-38 cm) - one vehicle - medium truck.

It is critical that the ice quality or type of ice is evaluated before you travel. Clear, hard, new ice is the only kind of ice recommended for travel or work. AVOID:

- slushy ice,
- ice on or near moving water (i.e., rivers, currents),
- ice that has thawed and refrozen, and
- layered or “rotten” ice caused by sudden temperature changes.

Other factors that weaken or “rot” ice:

- snow on ice that acts as a blanket to prevent hardening of ice, and
- pressure ridges due to wind or current pressure.

Section E29 Roof Work

Subsection E29(1) Where “an appropriate means of fall protection” has been implemented, control zones are not required. This section refers to the use of control zones to alert workers when entering within 2 metres of an unguarded edge. A control zone is considered “the 2 metre distance, perpendicular from an unguarded edge in the direction away from that unguarded edge.”

The use of a control zone is an approach to fall prevention that places special requirements on workers and work being performed on a nearly level working surface within 2 metres of an unguarded edge from which a worker could fall. Control zones can be used on surfaces having a slope of up to 4 degrees measured from the horizontal. A control zone is identified by a raised warning line or equally effective means of identifying a delineated area.

A control zone cannot be used if the level working surface on which work is being performed is less than 4 metres wide. In such circumstances, the employer must comply with Section 141 – General Requirements for Part X - Fall Protection.

The raised warning line or other equally effective means, such as barricades, must be placed at least 2 metres away from the edge. The warning method provides a visual and physical reminder of the presence of the hazard. (See Figure 10.1)

Figure 10.1 Example of a Control Zone marked out on a flat roof

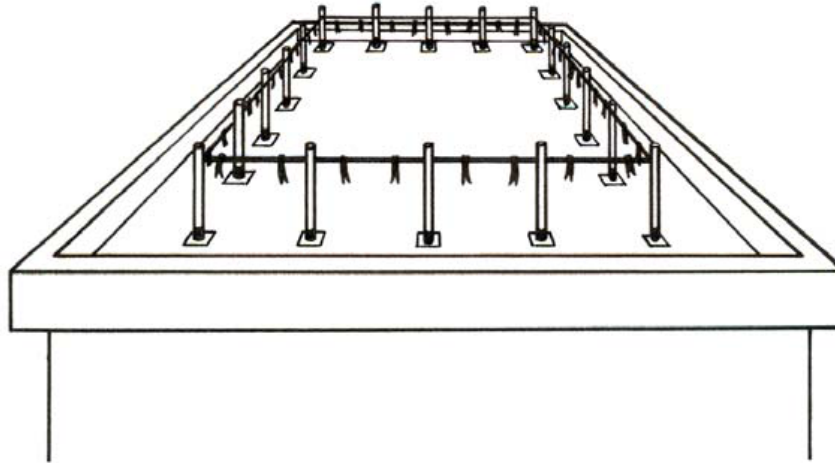

For compliance purposes, a raised warning line can consist of ropes, wires or chains, and supporting stanchions, and should be

(a) flagged or marked with highly visible materials at intervals that do not exceed 2 metres (6.5 feet),

(b) rigged and supported so that the lowest point (including sag) is not less than 0.9 metres (34 inches) from the walking or working surface and its highest point is not more than 1.2 metres (45 inches) from the walking or working surface,

(c) attached to each stanchion in such a way that pulling on one section of the line between stanchions will not result in slack being taken up in the adjacent section before the stanchion tips over, and

(d) the rope, wire or chain must have a minimum tensile strength of 2.2 kilonewtons (500 pounds force).

An “equally effective method” might be a substantial barrier (e.g. pile of materials or supplies, tall parapet, building system pipes and ducts, etc.) positioned between the worker and the unguarded edge, preventing the worker from getting to the edge. Since this substantial barrier is acting as a guardrail, it must at all times be at least 900 millimetres (36 inches) tall while the protected worker is using it. A simple wooden barricade is not considered to be substantial as it can be toppled, offering the worker inadequate protection.

Situations may arise where, on a large flat roof for example, work is performed at a significant distance away from an unguarded edge e.g. at a penthouse near the

centre of the roof. With the exception of when workers enter or leave the work area at an unguarded edge, workers have no contact with the edge. Upon accessing the roof, workers must proceed directly to their work area. Under such circumstances, a line defining a control zone is unnecessary.

Subsection E29(3) describes the use of a fully decked scaffold with toe boards installed continuously along the edge of the roof (See Figure 10.2); or roof brackets, guardrails and toe boards installed continuously along the edge of the roof (See Figure 10.3); or a fall arrest system (See Figures 10.4 & 10.5). One of these conditions must be met in order to work on a roof as described in this subsection.

Below are some examples of the type of conditions that must be met.

Figure 10.2 A fully decked scaffold with toe boards installed continuously along the edge of the roof

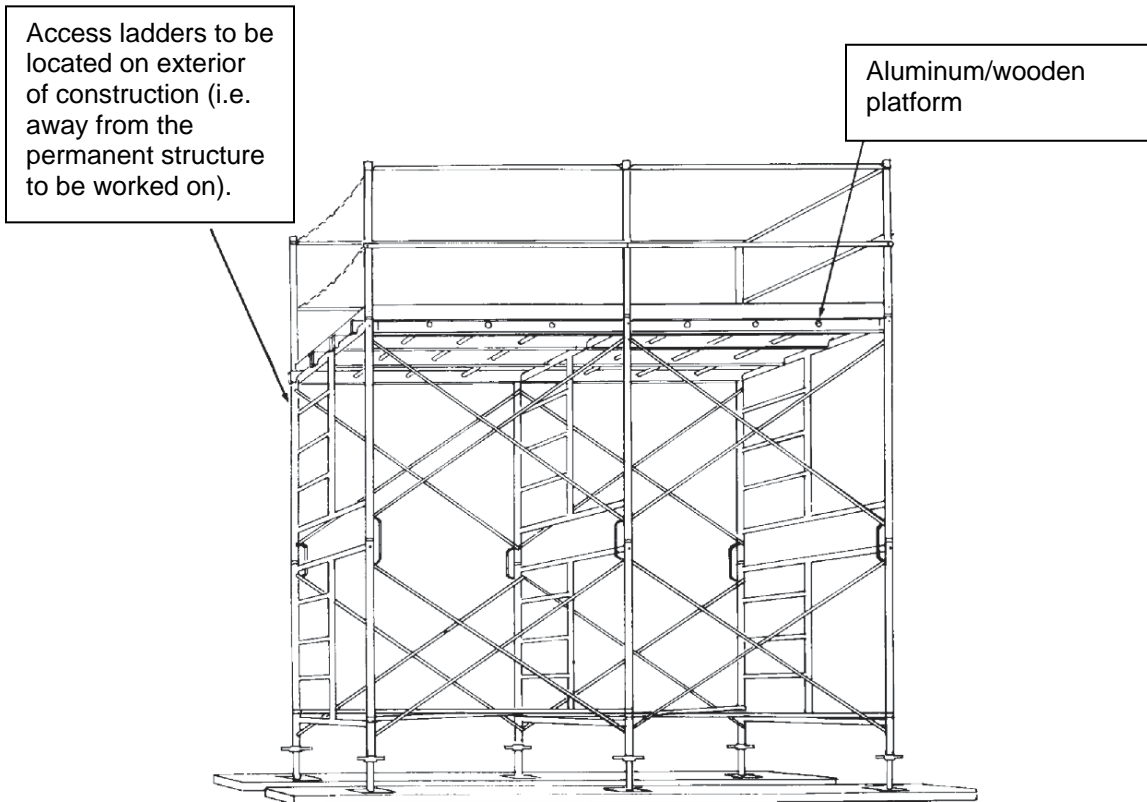

Figure 10.3 Roof brackets, guardrails and toe boards installed continuously along the edge of the roof

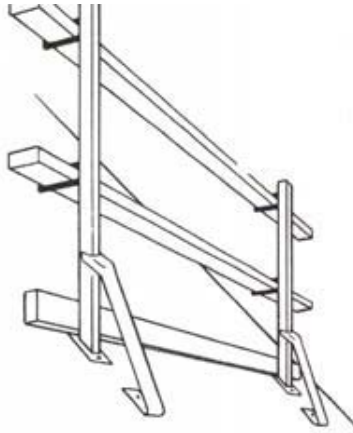

Figure 10.4 Fall Arrest systems

A fall-arrest system typically consists of

CSA (or equivalent) approved components including:

- Full-body harness
- Lanyard (with locking snap hooks or D-clips)
- Rope grab
- Lifeline
- Lifeline anchor

Full Body Harness and Fall Arrest System

TO adequate anchor point

Shock Absorber

Locking Snap Hooks

Rope Grab

Web Lanyard

Full Body Harness

Lifeline

Locking Rope Grab

Full Body Harness (front)

The diagram illustrates a worker from behind, wearing a full-body harness. A shock absorber is attached to the back of the harness. A web lanyard with a locking snap hook is connected to the harness and a rope grab. The rope grab is attached to a lifeline, which is anchored to an adequate anchor point. A close-up of the locking rope grab shows its mechanism for locking onto a rope. A front view of the full-body harness is also shown.

Figure 10.5 Another example of a Fall Arrest System



Section E29(4) describes the use of roof brackets (See Figure 10.6); or fully decked scaffold with toe boards installed continuously along the edge of the roof (See Figure 10.3); or a fall arrest system (See Figures 10.4 & 10.5). Two of these conditions must be met in order to work on a roof as described in this subsection.

Figure 10.6 Roof brackets

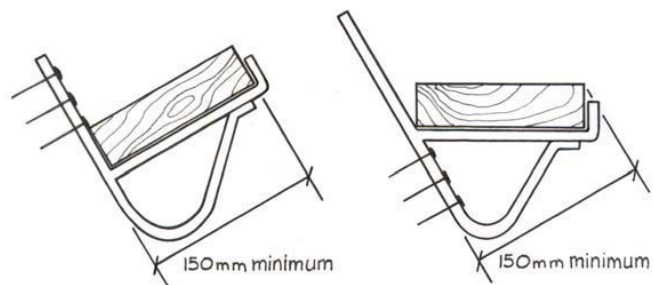

Section E29(5) describes the use of both roof brackets and a fall arrest system when working under the condition outlined in this section. See Figure 10.7 for an example of the requirements to comply with this section.

Figure 10.7 Roof brackets with planks and a fall arrest system

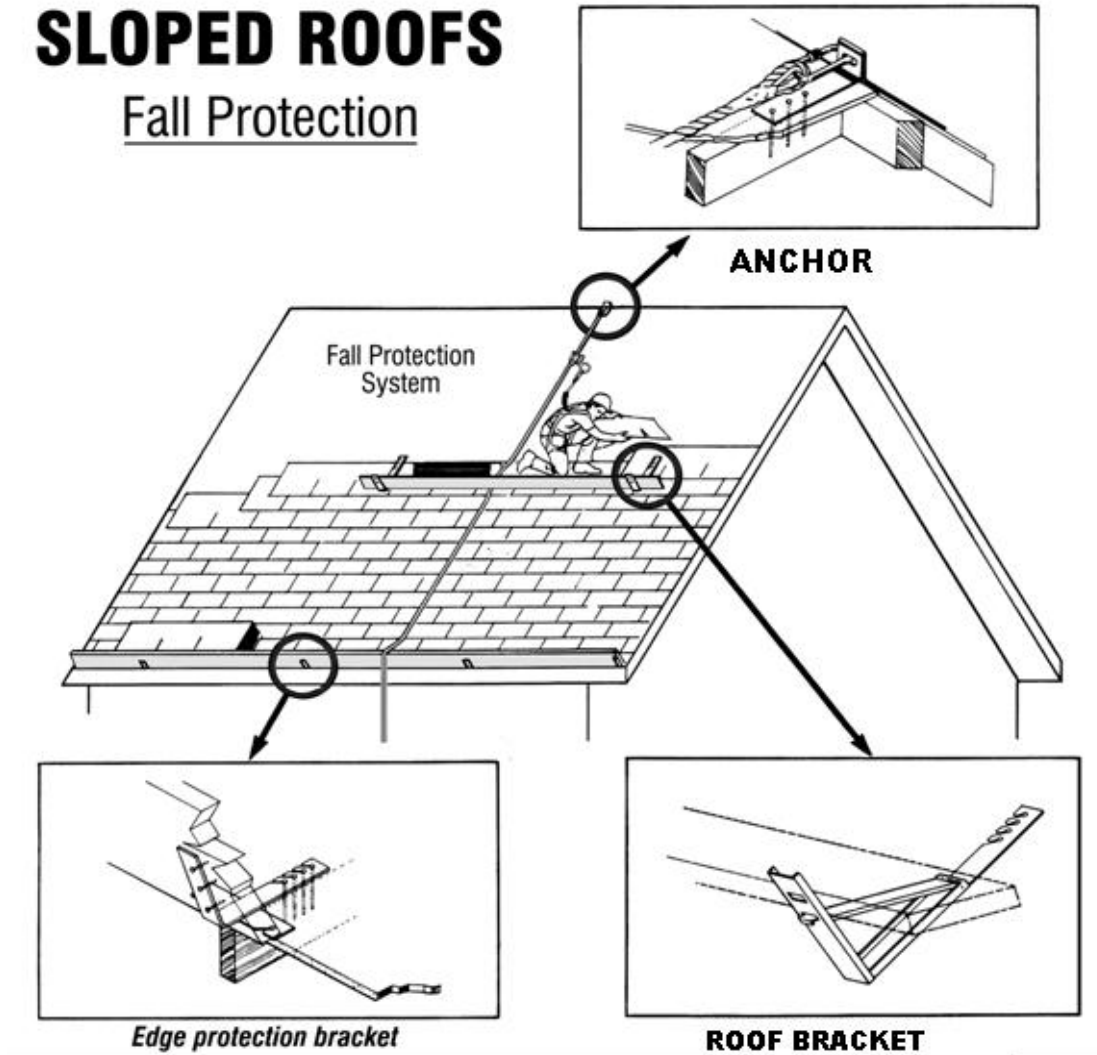

For the purposes of Subsection 29(5); edge protection brackets are not required to comply with the OHS Regulations; however it is suggested that this safe work practice be followed to help protect any workers working below the roof edge that may be unaware of the roofing activities above.

Section E38 Emergency Plan Risk Assessment

Where a risk assessment made under Subsection 38(1) concludes that removal by air is the most practicable method of evacuating injured workers, the employer's written procedures must conform to Transport Canada requirements.

Subsection E38(3)(a) Work at 'high angles' means a worker is in a position that cannot be reached by a standard stairway or elevator, and thus an injured worker on a stretcher could not be brought to a location accessible by an ambulance crew without use of specialized rescue equipment and techniques. Some examples are rock scaling while suspended on a rappel system, work being done using a swing stage, work on the jib or upper portions of a tower crane and work in an excavation.

Section E39 Emergency Procedures

Subsection E39(3) requires that an annual emergency drill be conducted to assess the effectiveness of the procedures and emergency exits that are required under Section 38 & 39. The procedures also need to be practiced so workers know their responsibilities and the procedures and equipment to be used.

Section E41 Emergency Training

Section 41 of the OHS Regulations involves the training of workers with regard to their involvement in fire prevention, evacuation and firefighting. It does not apply to professional firefighters.

Subsection E41(1) provides for "adequate instruction...applicable to his/her workplace". This provides for flexibility to adapt to the level of risk in the workplace. For example, in an office, workers would be expected to know the location(s) of the fire/evacuation alarm signals and the response to be made when the signal is activated.

In an industrial setting with a higher level of risk, for example, where workers must use a respirator or other specialized equipment to evacuate, more instruction is required and the necessary equipment must be available.

If a worker is expected to be part of the "workplace response" to contain a fire or other emergency, then training and instruction should be more detailed, and should clearly define the limits for response due to available equipment and training.