

**Guidelines for the Prevention
of
Soft Tissue Injuries**

May 12, 2003

TABLE OF CONTENTS

- (i) Foreword
- (ii) Acknowledgement

1. Introduction

- 1.1 Purpose
- 1.2 Interpretation
- 1.3 Overview
- 1.4 Application

2. General Principles

- 2.1 Program Elements
- 2.2 Consultation
- 2.3 Design
 - Design Principles
- 2.4 Education, Orientation and Instruction
 - General Instruction
 - Task Specific Instruction
- 2.5 Monitoring
- 2.6 Documentation

3. Risk Recognition

- 3.1 Purpose
- 3.2 Analysis of Workplace Injury Records
- 3.3 Consultation with Employees
- 3.4 Direct Observation (using a checklist)

General Risk Recognition Checklist

4. Risk Evaluation

- 4.1 Principles
- 4.2 Risk Factor “A” - Actions and Movements
- 4.3 Risk Factor “B” - Workplace and Workstation Layout
- 4.4 Risk Factor “C” - Working Posture and Position
- 4.5 Risk Factor “D” - Duration, Repetition and Frequency
- 4.6 Risk Factor “E” - Location of Loads and Distances Moved
- 4.7 Risk Factor “F” - Weights and Forces
- 4.8 Risk Factor “G” - Characteristics of Loads and Equipment
- 4.9 Risk Factor “H” - Work Organization
- 4.10 Risk Factor “I” - Work Environment
- 4.11 Risk Factor “J” - Skills and Experience
- 4.12 Risk Factor “K” - Age
- 4.13 Risk Factor “L” - Work Related Clothing
- 4.14 Risk Factor “M” - Special Needs
- 4.15 Risk Factor “N” - Other Factors
- 4.16 Further Advice on Risk Evaluation and Control

5. Risk Control

- 5.1 Principles
- 5.2 Control Factor #1 - Eliminating the Task

- 5.3 Control Factor #2 - Redesigning the Process and Task
 - Modify Object
 - Modify Actions, Movements and Forces
 - Modify Task - Mechanical Assistance
 - Modify Task - Team Lifting

- 5.4 Control Factor #3 - Redesigning the Work Area
 - Modify Workplace Layout
 - Tool Design and Modification
 - Controls Design
 - Rearrange Material Flow

- 5.5 Control Factor #4 - Providing Mechanical Handling Aids

- 5.6 Control Factor #5 - Providing Instruction
 - Task Specific Instruction
 - Instruction in the Principles of Manual Handling and Computer Workstation Setup

- 5.7 Control Factor #6 - Environmental Controls
 - Vibration
 - Working in Heat and Cold
 - Lighting
 - Housekeeping

- 5.8 Control Factor #7 - Developing Other Controls
 - Special Needs
 - Work Related Clothing
 - Incentive and Bonus Schemes
 - Work Organization
 - Other Administrative Controls

Appendices

- A - Sample Risk Recognition Checklist

- B - Completed Example of a Risk Recognition Checklist

- C - Sample Risk Evaluation Checklist

- D - Definitions

- E - Case Studies
 - Health Care Industry

- Construction Industry
- Retail Industry
- Office Ergonomics

(i) Foreword

The provisions in this guideline are not mandatory and have no legal status. The document is provided simply to help employers and workers recognize, evaluate and control ergonomics related risks which would otherwise be hazardous to the health and safety of workers and which could lead to soft tissue injuries. Employers and workers should be aware of the typical **signs** that indicate potential ergonomics problems such as:

- jobs that require the same motions every few seconds for several hours at a time;
- fixed or awkward work postures for extended periods, such as bending, bent wrists, kneeling, twisting, or squatting;
- use of vibration or impact tools or equipment for several hours consecutively;
- lifting, lowering, or carrying the maximum recommended weight limit;
- piece rate or machine-paced work for extended periods of time; and
- workers' complaints of physical aches and pains related to their work assignments.

The presence of these or similar indicators in a workplace should alert the employer and/or workers to take proactive measures before serious problems appear. Once potential ergonomics problems have been identified, they should be further evaluated in order to establish if there are ergonomic risks present. This guideline will assist in the evaluation process.

Typical ergonomics risks can include:

- repetition;
- forceful or prolonged exertions of the hands;
- vibration and/or cold temperatures;
- heavy lifting, pushing, pulling, or carrying;
- poor body mechanics;
- restrictive workstations;
- awkward postures; and
- hand tools that do not meet the requirements of the job.

To prevent soft-tissue injuries, these ergonomics risk factors should be eliminated or reduced using one or more controls.

This guideline can assist employers and workers to prevent soft-tissue injuries, and can also act as a resource to provide general instruction to workers and employers regarding ergonomics in the workplace.

(ii) Acknowledgement

The Department of Labour gratefully acknowledges copyright permission of the Commonwealth of Australia to reproduce material from the National Code of Practice for Manual Handling {NOHSC: 2005 (1990)}.

1. INTRODUCTION

1.1 PURPOSE

1.1.1 This guideline provides practical advice in preventing soft tissue injuries. The guideline outlines how to recognize, evaluate and control risks of soft tissue injury arising from physical tasks in the workplace.

1.2 INTERPRETATION

1.2.1 Soft Tissue Injury is a collective term used for a range of conditions characterized by discomfort or persistent pain in muscles, tendons and other soft tissues. It is usually associated with tasks which involve:

- (a) repetitive or forceful movement or both; and/or
- (b) maintaining constant or awkward postures.

1.2.2 Unsafe physical activity may cause a variety of soft tissue injuries and conditions including:

- muscle sprains and strains;
- injuries to muscles, ligaments, intervertebral discs and other structures in the back;
- injuries to soft tissues such as nerves, ligaments and tendons in the wrists, arms, shoulders, neck or legs;
- abdominal hernias;
- chronic pain.

Some of these conditions are known as repetitive strain injury (RSI), cumulative trauma disorder (CTD) and work-related musculoskeletal disorder (WRMSD). These injuries or disorders can occur either suddenly or over a prolonged period of time.

1.2.3 This guideline aims to provide detailed advice; however, it is not possible to deal with every situation which may be found in workplaces.

1.3 OVERVIEW

1.3.1 This guideline provides advice in the following areas:

- (a) General Principles (section 2);
- (b) Risk Recognition (section 3);
- (c) Risk Evaluation (section 4); and

(d) Risk Control (section 5).

1.4 APPLICATION

1.4.1 This guideline applies if you are:

- an employer, because it will help to work out which tasks in your workplace could cause soft tissue injuries and show you how to control the risk;
- a designer, manufacturer, importer or supplier because it will help you ensure that users of your product are not exposed to the risk of soft tissue injury;
- a member of an occupational health and safety committee, an employer's health and safety representative, an employee or anyone else interested in reducing soft tissue injuries in workplaces.

2. GENERAL PRINCIPLES

2.1 PROGRAM ELEMENTS

2.1.1 There are at least three key elements in a successful ergonomics program. This guideline provides guidance and assistance in understanding the role of the following elements:

- (a) **recognition** of risks in the workplace likely to cause soft tissue injury;
- (b) detailed **evaluation** of the risks; and
- (c) principles and examples of **control** measures to eliminate or reduce the risks.

2.1.2 Figure 1 summarizes the three program elements.

2.2 CONSULTATION

2.2.1 Employers should develop a method to recognize and evaluate ergonomics hazards and, where necessary, implement controls. This should be done in consultation with employee(s) who are required to perform the tasks, as well as with the health and safety committee or the worker health and safety representative. This consultation should occur when:

- (a) planning for the introduction of new or modified operations and tasks or when reviewing existing operations. It should be done in time to allow for changes arising from the consultation to be made;
- (b) recognizing problem areas so that priorities for evaluation can be established;
- (c) determining the approach to be used in evaluating operations and tasks;
- (d) deciding on control measures to reduce risk factors; and
- (e) reviewing the effectiveness of implemented control measures.

2.2.2 Consultation may occur through formal and/or informal processes, and involve direct and/or representational participation.

Figure 1 - Summary of three program elements

1 Risk Recognition

- ! regular workplace inspections
- ! consultation with employees
- ! task analysis
- ! direct observation
- ! accident/incident investigation
- ! analysis of workplace injury records

2 Risk Evaluation

- ! duration, repetition and frequency
- ! workplace and workstation layout
- ! working posture and position
- ! actions and movements
- ! location of loads and distance moved
- ! weights and forces
- ! characteristics of loads and equipment
- ! work organization
- ! work environment; including lighting, temperature and vibration
- ! skills and experience
- ! characteristics of workforce; including age, height and size
- ! work related clothing
- ! special needs (temporary or permanent)

3 Risk Control

Re-engineer Operations

- ! modify or add equipment, tools, and supplies
- ! modify workplace layout
- ! modify workplace environment (lighting, vibration, sound, temperature)
- ! rearrange operations flow

Re-engineer Task Performance

- ! different actions, movements, and forces
- ! modify work practice (eg. team lifting)
- ! different task organization

Instruction

- ! instruction in general ergonomics principles
- ! specialized training

Other Administrative Controls

- ! purchasing
- ! job rotation
- ! policies and procedures
- ! written safe work procedure
- ! housekeeping

****** Consultation should take place with employees throughout all three of these program elements******

2.3 DESIGN

2.3.1 Employers should recognize risks which may expose workers to soft tissue injury by ensuring, as far as reasonably practicable, the following:

- S buildings, equipment and containers used in the workplace are safely designed, constructed and maintained;
- S work practices and procedures are carried out in a safe way; and
- S the working environment is designed and maintained in a safe and healthy manner.

2.3.2 It is more cost effective to reduce or eliminate hazards at the design stage by including ergonomics considerations. It costs more to redesign or modify workplaces or work processes after they are in place.

2.3.3 Purchasing specifications should identify the uses or functions of the buildings, equipment, tools and supplies. For example, when purchasing safety footwear in a fish plant, ensure that the soles are non-skid; or when purchasing an office chair, specify whether it will be used by one person or a number of people.

2.3.4 The design of buildings, equipment, tools and supplies in workplaces needs to provide for a range of physical characteristics of the workforce. Human dimensions (i.e., size and shape) and capabilities should be taken into account to provide an optimum match between the workplace or equipment and many users.

Design Principles

2.3.5 Employers need to be aware of the enormous range of physical dimensions, for example, height and reach, to be found in the workforce. These dimensions will have implications for task design and the selection and use of equipment and furniture.

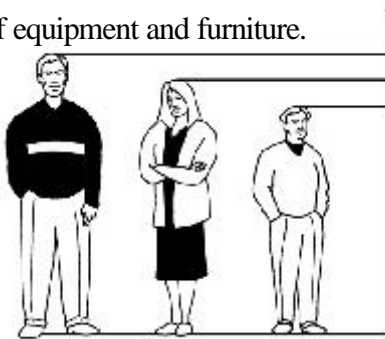

Figure 2 - Workplaces should incorporate adjustable features to accommodate people who are not average size.

2.3.6 Equipment and furniture should be designed so that they can be used safely. It is also desirable to design activities and tasks to suit the capacity of the widest possible range of the workforce. This avoids any chance of discrimination against particular groups. The employer is required to consider the safety of each employee, and not simply to design a system which may be safe for an average person in the workforce.

2.3.7 The following general principles for reducing risks associated with physical tasks should be incorporated into the design of buildings, workplaces, workstations, and equipment:

- (a) minimize the lifting and lowering forces exerted;
- (b) avoid the need for bending, twisting and reaching movements; and
- (c) minimize repetition and duration of tasks.

2.3.8 The following details should be considered at the design stage:

- (a) size, surface characteristics, stability and weight of objects;
- (b) workplace layout and general environment;
- (c) work postures and space requirements; and
- (d) work organization requirements.

2.4 EDUCATION, ORIENTATION AND INSTRUCTION

2.4.1 It is recommended that:

- (a) employers ensure that new and current employees, who are at risk of soft tissue injuries, are instructed in risk recognition and evaluation;
- (b) employers ensure that a worker, who is assigned work which requires specific measures to control the risks of soft tissue injuries, is instructed in the use of those measures; including work procedures, mechanical aids and other administrative controls; and
- (c) when an employee has received appropriate instruction to minimize exposure to risk factors, the employee use that instruction wherever possible.

2.4.2 In addition to the employees who are directly at risk, other target groups which require instruction include:

- (a) supervisors and managers of employees who are at risk;
- (b) worker health and safety committee or worker health and safety representatives; and
- (c) staff responsible for work organization and job and task design.

2.4.3 Instruction objectives should be established in order to:

- (a) recognize and understand the many risk factors involved in physical work activities;
- (b) improve awareness of hazards, their associated risks, and all the appropriate control measures; and
- (c) promote and use safe work practices.

General Instruction

2.4.4 The instruction program should be specific to the tasks performed by the group being instructed.

2.4.5 Topics should include:

- (a) potential health risks from physical work;
- (b) the magnitude of the ergonomics problem;
- (c) job and individual risk factors associated with soft tissue injuries;
- (d) control strategies with primary emphasis on work organization, operation and task design;
- (e) safe work practices;
- (f) safe use of mechanical aids and other administrative controls;
- (g) the responsibilities of all parties;
- (h) the legislative requirements; and
- (i) how the ergonomics program is administered.

Task Instruction

2.4.6 In addition to the general instruction outlined above, refer to Task Specific Instruction (section 5.6) of the Guidelines for suggestions regarding safe work practices.

2.5 MONITORING

2.5.1 Reducing risks does not end just with the implementation of the change. The effectiveness of new control measures needs to be reviewed periodically to ensure that the objectives are being achieved and that there are no unforeseen negative outcomes.

2.5.2 It may be necessary to try risk controls on a trial basis before making them permanent. Some ideas for risk control may look promising, but don't work so well in practice. Consult your employees' health and safety representatives, if practicable, about the effectiveness of risk controls.

2.5.3 A risk evaluation previously carried out for a particular task may no longer adequately evaluate the risk of soft tissue injury. This may be because:

- the task has changed in some way;
- new information about the task or the evaluation may have arisen;
- a report of soft tissue injury associated with the task may have been made.

In these circumstances, the risk evaluation should be reviewed and, if necessary, revised. If the revised evaluation shows a different level of risk than that originally evaluated, you will need to review the original risk controls and alter them if necessary.

2.5.4 Any review and evaluation should consider the following key elements:

- (a) Have risks been adequately recognized, evaluated and controlled?
- (b) Is there adequate feedback/consultation between employers and workers?
- (c) Are education and instruction programs developed, and are workers appropriately instructed?
- (d) Have the number of ergonomics related injuries and incidents decreased?

2.6 DOCUMENTATION

2.6.1 Records associated with the implementation of an ergonomics program should be maintained in a central location and be available to the health and safety committee, to the worker health and safety representative and to occupational health and safety officers. Such records will make the task of review and evaluation easier.

2.6.2 It is advisable to record your risk control decisions and the agreed times by which actions are to be completed. Make sure that all relevant people know who will be responsible for implementing the change. You can use the comment section of the checklist in Appendix C to document your risk controls.

2.6.3 Where applicable, the records should include information on:

- (a) the soft tissue injury prevention program;
- (b) risk recognition reports;
- (c) risk evaluation reports;
- (d) risk control measures implemented and the date of implementation;
- (e) design modifications to, and specifications for buildings, operations and tasks;
- (f) instruction and education activities;
- (g) names and dates of people who were instructed;
- (h) consultation with employees;
- (i) job site analyses;

- (j) work station reviews;
- (k) names of individuals who have completed any of the above activities; and
- (l) name(s) of individuals responsible for workplace health and safety.

The remaining sections (sections 3, 4 and 5) of this Guideline provide the reader with helpful information for **recognizing, evaluating and controlling** the risk factors for soft tissue injury in the workplace.

3. RISK RECOGNITION

3.1 PURPOSE

- 3.1.1** Risks in the workplace should be recognized, evaluated and controlled. The first step in this process is **risk recognition**. This section provides a guide for recognizing physical tasks likely to be a risk for soft tissue injury.
- 3.1.2** The purpose of risk recognition is to identify the risk factors which will need to be evaluated and then prioritized in order of severity.
- 3.1.3** There are three steps to risk recognition:
- (a) analyze workplace injury records;
 - (b) consult with employees; and
 - (c) directly observe or inspect the task or work area.
- 3.1.4** If any of these three steps recognize a risk, then section 4 of this guideline provides advice regarding **risk evaluation**.

3.2 ANALYSIS OF WORKPLACE INJURY RECORDS

- 3.2.1** Workplace injury records should be examined to recognize when, where, why and how soft tissue injuries have occurred.
- 3.2.2** Consider the following when reviewing injury records: *(Workplace Health, Safety and Compensation Commission can provide some assistance in this area)*
- (a) the area of the workplace where the injury occurred;
 - (b) the occupation and job demands of the injured person;
 - (c) time of day of the accident/incident;
 - (d) duration of shift worked (eg. night or day);
 - (e) the part of the body injured - examples include: back, neck or shoulder;
 - (f) the nature of the injury - examples include: strain, sprain, or inflammation;
 - (g) the type of accident - examples include: overexertion and physical stress in lifting objects, or slips and falls while handling objects; and
 - (h) the source of injury (eg. vats, pots, slippery floors).
- 3.2.3** It is often useful to examine overall injury records to find out the **injury frequency rate** and **injury severity rate** (see Appendix D for definitions and formulas) of injuries. Comparisons of the frequency rate and severity rate between locations, occupations or tasks can help recognize areas of potential high risk.

3.2.4 Higher frequency rates, severity rates, and/or incidence rates indicate priority areas.

3.3 CONSULTATION WITH EMPLOYEES

3.3.1 It is essential to consult with employee(s) performing the tasks because they are often more aware of the risk of soft tissue injuries associated with their jobs.

3.3.2 During the risk recognition and risk evaluation (section 4) phases, consultation with employee(s) carrying out the tasks and with the health and safety committee or worker health and safety representative may provide information about associated risk factors. Employee(s) may indicate particular tasks or movements which are strenuous or difficult to perform or which cause fatigue.

3.4 DIRECT OBSERVATION (USING A CHECKLIST)

3.4.1 The direct observation of work areas and of the tasks being performed will help recognize risks. The features of unsafe physical activity are explained on pages 12-15.

3.4.2 Workplace inspections, audits and walk-through surveys, using checklists, are examples of direct observation. These three direct observation tools work best when they are specific to the organization or industry. A General Risk Recognition Checklist, is provided on pages 16-18. Directions on how to use the Checklist are provided below. The sample checklist can also be found in Appendix A and can be copied for use in the workplace. Appendix B contains a completed example of the Checklist.

3.4.3 The space provided at the top of the checklist enables the person performing the general risk recognition to record relevant information regarding:

- (a) the building and/or equipment (description of work location);
- (b) details of the task and/or workstation (task description);
- (c) the person conducting the evaluation on behalf of the employer;
- (d) the name of the co-chairs of the health and safety committee or worker health and safety representative consulted in the process;
- (e) the name(s) of worker(s) (optional); and
- (f) any other person(s) involved in the evaluation.

3.4.4 If any of the questions in the checklist result in a “yes” answer, **further evaluation** of that risk factor is required. Generally, the more **yes** answers that result for a particular task, then the higher the priority for risk assessment of that task.

Repetitive or sustained application of force

Repetitive application of force means using force repeatedly over a period of time to move or support an object. For example:

- lifting and stacking goods onto a pallet
- gripping and handling bricks when bricklaying
- using a nailgun to fix pickets to a fence
- pressing a pedal or button to operate a power press
- typing and other keyboard tasks



*Sawing requires the **repetitive application of force**. Holding the timber steady requires the **sustained application of force**.*



*Handling bricks and trowel while bricklaying requires the **repetitive application of force**.*

Sustained application of force occurs when force is applied continually over a period of time. For example:

- pushing or pulling a trolley around hospital wards
- holding down a trigger to operate a power tool
- supporting drywall while fixing it to a ceiling
- supporting a patient walking down a corridor
- continuing to hold a tool when not using it

*It takes the **repetitive application of force** to chop through this **meat**. Holding the meat steady requires the **sustained application of force**.*



*Pushing the wheelbarrow across the plank requires the **sustained application of force**.*

Repetitive or sustained awkward posture

An awkward posture is one in which any part of the body is in an uncomfortable or unnatural position.

Repetitive awkward postures include:

- reaching sideways to pick up goods from a conveyor belt and pack them
- picking up items from a conveyor belt and turning them over for inspection and packing

Sustained awkward postures include:

- crouching to service equipment or a vehicle
- lying underneath a vehicle and reaching upwards to service it
- kneeling while trowelling concrete or laying carpet
- leaning over a bath while bathing a patient
- continually standing while operating a power press with foot pedal controls

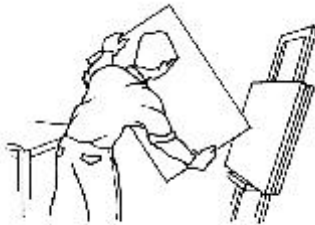

When stacking these sheets, **repetitive and sustained awkward postures** must be adopted (twisting and bending the back, working with the arms outstretched, and bending and twisting the wrists).

This writing task requires a **sustained awkward posture** (prolonged bending of the back and neck).



Pushing and steering this trolley demands **sustained awkward postures** (bending and twisting the back and neck) and the **sustained application of force** (to move the trolley).

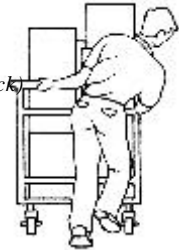

Pouring from the bucket into the drum requires a **sustained awkward posture** of the back, neck and arms and the **sustained application of force** (to hold and pour)

The way this computer is set up requires **sustained awkward postures** (bending the back, bending and twisting the neck and bending the wrists).



Pruning plants can involve a **sustained awkward posture** (bending the back) and the **repetitive application of force** (using shears).

Repetitive or sustained movement

Repetitive or sustained movement means using the same parts of the body to repeat similar movements over a period of time.

Examples of tasks involving repetitive or sustained movement include:

- painting
- lifting goods from a conveyor belt and packing them in a carton
- typing and other keyboard tasks
- assembly work in manufacturing
- using a socket and ratchet or wrench to unscrew long bolts

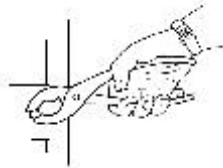

Repetitive movements of the fingers are required to open these pliers because the tool has no return spring. Repetitive use of pliers often requires **awkward movements and postures** of the hand.

Application of high levels of force

Application of high levels of force occurs in any task that employees would find difficult to do because of the effort required. For example:

- lifting or carrying a heavy object
- pushing or pulling an object that is hard to move
- operating tools with squeeze grips that are too far apart
- throwing or catching objects
- lifting a heavy item from a high shelf

Watch for any tasks that employees describe as very physically demanding. If an employee needs help to do a particular task, or if a stronger person is assigned to do the task, this indicates that the task requires the application of high levels of force.



Using a concrete saw requires the applications of high force and sustained awkward postures of the back and neck.

A heavily loaded trolley demands the application of high force to move and steer it.

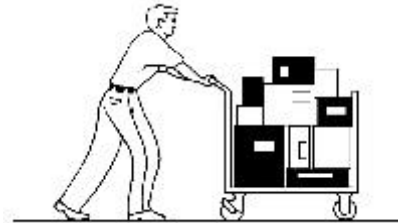

Using tin snips can require the application of high force. A bent wrist and wide grip increase the force that must be exerted.

Exposure to sustained vibration

Vibration transferred from tools or machinery to the operator's body can increase the risk of soft tissue injuries.

Exposure to sustained vibration occurs in tasks such as:

- using impact wrenches, chainsaws, jack-hammers, grinders, drills or vibrating plates
- operating earth-moving equipment
- driving a tractor



The use of jack-hammers and similar tools involves exposure to sustained hand-arm vibration.



Seated operators of mobile equipment can be exposed to sustained whole-body vibration.

Handling of live people or animals

Handling of live people or animals is hazardous because their movements can't always be anticipated. Examples include:

- assisting a patient to walk down a ramp into a swimming pool
- treating a panic-stricken animal in a veterinary clinic

*Staff must be prepared for **unexpected movements** when transferring a patient from bed to chair. This unexpected movement **may result in use of high force and adopting awkward postures***



Handling of loads that are unstable, unbalanced or difficult to hold

Loads that are unstable or unbalanced can move or change shape suddenly, or are uneven and heavier on one side.

Loads that are difficult to hold include loads that are very large, slippery, floppy, sharp, hot, cold, toxic or unpleasant.

For example:

- lifting a sack of flour
- carrying an open cooking pot full of soup
- carrying a large sheet of drywall
- carrying a laundry bag full of dirty linen

*The ladder is an **unstable load**. If it tilts, high force must be exerted to control it.*

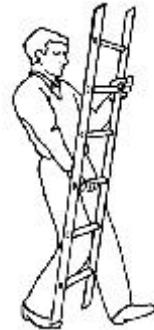

*Transferring a patient may involve **unexpected movements**, the application of **high force** and the adoption of **awkward postures**.*

*The **application of high force** may be required if the patient becomes unsteady. Supporting the patient may require the **sustained application of force** and **sustained awkward postures** may occur.*

RISK RECOGNITION CHECKLIST

Job Title: _____ Date: ___/___/___

Description of Work Location: _____

Task Description: _____

Evaluated by: _____ (Name) _____ (Title)

~~Health and Safety Committee Co-chairs or Worker Health and Safety Representative:~~ _____

Worker(s) Names (Optional)

Names of others involved in the risk recognition process: _____

Following is a list of key risk factors. If “yes” is the answer to any of these questions, it means there is need for further evaluation of the risk factors as outlined in section 4 - Risk Evaluation. Generally, the more yes answers there are for any particular task or section of the checklist, then the higher the priority for **further risk evaluation** of that task.

MOVEMENTS, POSTURE AND LAYOUT DURING PHYSICAL WORK

			Comments
1.	Is there frequent or prolonged bending down to where the hands pass below mid-thigh height?	9 Yes 9 No	_____
2.	Is there frequent or prolonged reaching	9 Yes 9 No	_____

above the shoulder?

				Comments
3.	Is there frequent or prolonged bending due to extended reach forward?	9 Yes	9 No	_____
4.	Is there frequent or prolonged twisting of the back?	9 Yes	9 No	_____
5.	Are awkward postures used frequently or over prolonged periods; i.e., postures where a joint reaches its end range of motion. (See illustrations of awkward postures section 4.4.3, figure 3, in the Guidelines)?	9 Yes	9 No	_____
6.	Do pressure points occur during the performance of the task?	9 Yes	9 No	_____
7.	Is sitting or standing in one place required for prolonged periods without a rest period?	9 Yes	9 No	_____
8.	Is the task performed frequently or for long periods of time by the employee(s) without a rest period or change of task?	9 Yes	9 No	_____

MANUAL HANDLING

9.	Are loads moved or carried over long distances?	9 Yes	9 No	_____
10.	Are weights handled:	9 Yes	9 No	_____
	a) from a seated position, perceived to exceed individual capabilities?			
	b) in a position, other than a seated position, perceived to exceed individual capabilities?	9 Yes	9 No	_____
	c) more than 32kg (70.5 lbs) or as per current edition of American Conference of Government Industrial Hygienists, Lifting TLVs?	9 Yes	9 No	_____

Note: The weight noted here is not intended to be the maximum limit but is an important factor to be considered when evaluating and controlling risk.

11. For pushing, pulling, carrying, holding or other applications of force, are large forces exerted or large weights used? **9** Yes **9** No _____

Comments

12. Are the loads difficult or awkward to handle, for example, due to their size, shape, temperature, instability or unpredictability? **9** Yes **9** No _____

13. Is it difficult or unsafe to get adequate grip of the load? **9** Yes **9** No _____

WORK ENVIRONMENT

14. Is the task performed in a restricted work space? **9** Yes **9** No _____

15. Is the lighting inadequate for safely performing the task? **9** Yes **9** No _____

16. Is the climate particularly cold or hot? **9** Yes **9** No _____

17. Are the floors cluttered, uneven, slippery or otherwise unsafe? **9** Yes **9** No _____

18. Is the working environment too noisy for the task? **9** Yes **9** No _____

19. Are workers exposed to vibration when using tools, machinery and/or equipment for the task? **9** Yes **9** No _____

INDIVIDUAL FACTORS

20. Is the employee new to the work or returning from an extended period away from work? **9** Yes **9** No _____

21. Are there age-related factors, disabilities or other special factors that may affect task performance? **9** Yes **9** No _____

22. Does the employee's clothing or personal protective equipment interfere with task performance? **9** Yes **9** No _____

23. Are the skills and experience of the worker inadequate for the task? **9** Yes **9** No _____

4. RISK EVALUATION

4.1 PRINCIPLES

- 4.1.1** An employer should undertake an examination and evaluation of those areas where ergonomics risks have been recognized.
- 4.1.2** Listed in section 4.1.5 are the factors to be taken into account when evaluating tasks; and these factors highlight the complex nature of soft tissue injury.
- 4.1.3** Risk recognition (as outlined in section 3) should be undertaken on a regular basis and, when indicated, risk evaluation should be carried out. **Risk evaluation** is particularly critical whenever:
- a) an injury has occurred arising from a work process and/or practice;
 - b) a work process, practice and/or equipment is introduced or modified.
- 4.1.4** In evaluating a job or a task, all risk factors should be considered; and in determining appropriate controls, the interaction of all the factors should be taken into account. In most work situations, the risk evaluation method in this section (4) will be sufficient to evaluate the risk of soft tissue injuries. In some circumstances, however, further evaluation may be required. Section 4.16 explains when further evaluation may be needed.
- 4.1.5** To assess whether physical activity is likely to cause soft tissue injury, the following factors need to be evaluated:
- (a) actions and movements;
 - (b) workplace and workstation layout;
 - (c) working posture and position;
 - (d) duration, repetition and frequency;
 - (e) location of loads and distances moved;
 - (f) weights and forces;
 - (g) characteristics of loads and equipment;
 - (h) work organization;
 - (i) work environment; including lighting, temperature and vibration;
 - (j) skills and experience;
 - (k) characteristics of workforce; including age, height and size;
 - (l) work related clothing;
 - (m) special needs (temporary or permanent); and
 - (n) any other factors considered relevant.
- 4.1.6** The following are questions to help evaluate these risk factors. A sample Risk Evaluation Checklist can be found in Appendix C and can be copied for use in the workplace. **It is advised to read Section 5 (Risk Control) before using the Risk Evaluation Checklist.**

4.2 RISK FACTOR “A” - ACTIONS AND MOVEMENTS

4.2.1 When performing a task, a person’s actions or movements can lead to soft tissue injuries if not carried out correctly.

4.2.2 Answering YES to any of the following questions indicates an increased risk:

- (a) Are actions or movements causing undue discomfort or pain?
- (b) Are actions performed with sudden or jerking movement?
- (c) Are tasks performed in an unbalanced and/or uncomfortable position?
- (d) Does the task require a full range of joint movement which is prolonged or repetitive?
- (e) Is there repetitive bending, twisting, or overreaching?
- (f) Is a load shared **unevenly** between both hands, or lifted by one hand only?
- (g) Is an object pushed or pulled across the front of the body?
- (h) Is there a need to bend over to one side to lift or move an object?
- (i) Are several tasks performed in one position where some might be better performed in a seated position and the others are best performed in a standing position?

4.3 RISK FACTOR “B” - WORKPLACE AND WORKSTATION LAYOUT

4.3.1 Posture, working height, working technique, duration, frequency and other work actions and movements are all affected by the positioning of the workstation(s), equipment, controls, displays, tools and other material in relation to each other and in relation to the employee.

4.3.2 Wherever possible, the layout should permit the employee(s):

- (a) to adopt an upright and forward facing posture;
- (b) to have good visibility of the task; and
- (c) to perform the majority of tasks at about waist height and within easy reach.

4.3.3 Answering YES to any of the following questions indicates an increased risk:

- (a) Is the layout **inappropriate** for the task and the physical dimensions of the employee(s) performing the task?
- (b) Is there **inadequate** space for movements involved in the task?
- (c) Are appropriate mechanical handling aids **not readily** available for the task?
- (d) Are the working heights **fixed or not matched** to the size of the employees and the tasks?
- (e) Is the space for moving legs and feet **inadequate or obstructed**?
- (f) Can the order of tasks be rearranged to reduce the number of movements performed by the employee?

4.4 RISK FACTOR “C” - WORKING POSTURE AND POSITION

4.4.1 Work activities should permit the employee to adopt several different but equally healthy and safe working postures. One posture should not be maintained for long periods without the opportunity to change posture through variation of activity or rest.

4.4.2 Awkward posture, including bending and/or twisting of the spine, should be avoided; especially when it is prolonged or repetitive.

4.4.3 Answering YES to any of the following questions indicates an increased risk:

- (a) Is the employee required to obtain an object which is difficult to reach or grasp?
- (b) During manual handling, is there frequent or prolonged:
 - (i) above shoulder reaching?
 - (ii) forward bending of the back?
 - (iii) twisting of the back?
 - (iv) sideways bending of the back?

Figure 3



Avoid above shoulder reach



Avoid forward bending of the

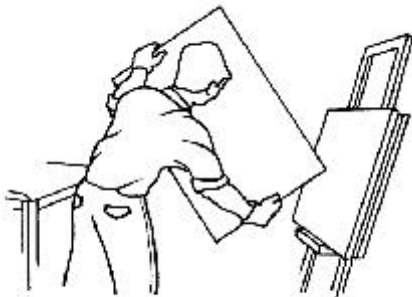

*Avoid twisting of the
back*



*Avoid sideways bending of the
back*

4.5 RISK FACTOR “D” - DURATION, REPETITION AND FREQUENCY

- 4.5.1** The risk of injury rises with the increasing frequency, repetition and duration of physical activity by any one employee in a work period. How often and for how long a task is performed are key risk factors to be considered.
- 4.5.2** Problems with frequency and duration are not restricted to lifting or lowering of loads. Pushing, pulling, carrying and holding loads can also be a problem if performed frequently or for prolonged periods.
- 4.5.3** The same physical task repeated over periods of time can be tedious and can cause boredom which results in the employee(s) being less alert and more complacent. This situation can have important safety consequences.
- 4.5.4** There are several factors which influence a person’s ability to continue prolonged activity. These include the energy a person has stored in his/her body ready to use, and a person’s physical fitness relative to the work load.
- 4.5.5** Physical tasks involving the use of smaller muscle groups (such as in the hands) should not be overlooked in evaluating risks because these muscles tire quickly when overused. This overuse can occur when these small muscles are held in the same position for long periods of time or when there is prolonged repetitive movement.
- 4.5.6 Answering YES to any of these questions indicates an increased risk:**
- (a) Are the same tasks being performed repeatedly or frequently throughout the duration of the work period?
 - (b) Are small muscle groups overused by being held in the same position for long periods of time or through prolonged repetitive movement?

4.6 RISK FACTOR “E” - LOCATION OF LOADS AND DISTANCES MOVED

- 4.6.1** Distances over which loads are manually handled should be as short as possible. Risk is increased when the load is carried a greater distance. Therefore, when distances are increased, loads should be reduced.
- 4.6.2** The risk of injury is increased if the load is located above the person’s shoulder height or below mid-thigh height or if other extended reaches are required. An increased risk also occurs where the load must be placed or held in a specific position.

4.6.3 Answering YES to these questions indicates an increased risk:

- (a) Could distances over which loads are moved be shorter?
- (b) Are loads which are to be moved located above shoulder height or below mid-thigh height?

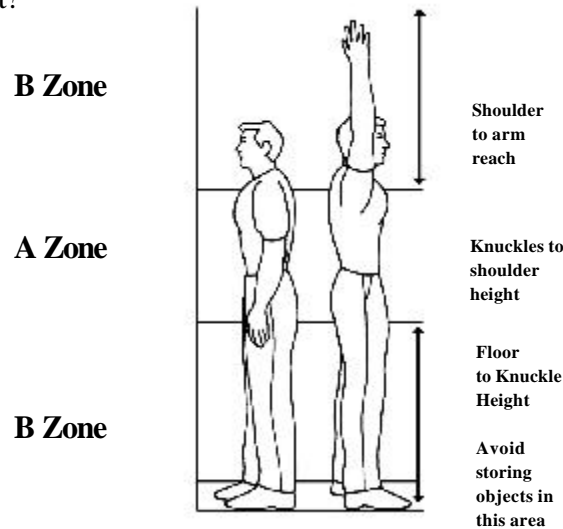

Figure 4 - Optimize location of loads. The best height range for handling loads is around waist level, with lifting between the knuckle and the shoulder being acceptable. Frequently used objects should be stored in the “A” zone. Seldom used objects should be stored in the “B” zone.

4.7 RISK FACTOR “F” - WEIGHTS AND FORCES

4.7.1 The weight of any load which is manually handled should be considered in relation to other key risk factors; in particular:

- (a) frequency and duration;
- (b) position of load relative to the body;
- (c) distance(s) moved; and
- (d) characteristics of the load (eg: sharp edges, unevenly shaped, unusually large).

4.7.2 Where heavier objects are handled, more care is needed in the evaluation of risk and in the application of appropriate controls.

4.7.3 For lifting, lowering, pushing, pulling, carrying or holding tasks, the force required should not exceed the safe physical capability of the worker.

4.7.4 Apart from lifting, lowering and carrying objects, many tasks in industry involve the use of force to push, pull, hold or restrain objects. The posture required and the working conditions affect the risk associated with applying such force.

4.7.5 The muscular effort required to lift, lower or carry a load depends on more than just the weight of the object. Therefore, there are no specific weight limits noted in this section. Muscular effort is also determined by the postures, movements, forces, frequency and duration involved in the task.

This means that even a relatively small weight may be difficult to lift and require the application of high force. Therefore, it is difficult to specify safe maximum weights that would apply to different tasks, or even to similar tasks done under different circumstances.

4.7.6 As muscular effort increases, more stress is placed on structures in the body such as muscles, ligaments, joints and intervertebral discs. The greater the effort and stress on the body, the greater the risk of soft tissue injury.

4.7.7 To determine whether a particular lifting task involves a risk, use the checklist in Appendix C. This takes into account all the factors that contribute to risk, including weight.

4.7.8 When evaluating tasks involving lifting, lowering or carrying, bear in mind that, in general:

- the bigger, heavier or bulkier the load, the greater the effort required to handle it and the greater the risk;
- the further the load is from the body, the greater the effort required and the greater the risk;
- lifting that requires poor postures puts more stress on the body and increases the risk;
- the higher the load needs to be lifted, the greater the effort required and the greater the risk;
- as frequency and duration increase, so does the risk;
- lifting or carrying a load with one hand or to one side of the body puts more stress on the body than handling the load with both hands.

4.7.9 Answering YES to any of the following questions indicates an increased risk:

- (a) When sliding, pulling or pushing an object, is the object difficult to move?
- (b) Is the employee required to exert a large force while seated?
- (c) Is the employee required to push/pull while seated without having good seating and solid foot support?

Figure 5 - The application of force in two situations.

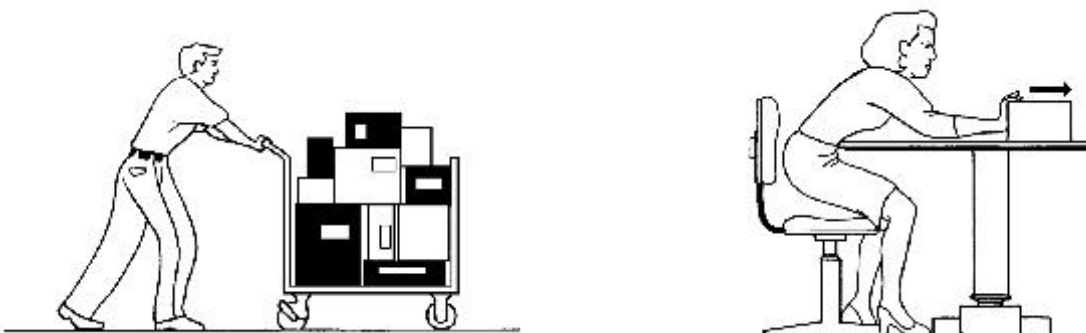

4.8 RISK FACTOR “G” - CHARACTERISTICS OF LOADS AND EQUIPMENT

4.8.1 When evaluating risk, there are load characteristics to consider, in addition to weights and forces. These characteristics can include: dimensions, shape, stability, rigidity, surface texture, temperature and handles (eg. moving a person or patient, or object of unknown weight).

4.8.2 The requirement for gloves or similar apparel also needs to be evaluated in relation to comparing risks. Gloves may protect against hand injuries, such as abrasions and burns, but they will affect grip stability, dexterity and strength.

4.8.3 The handling of live animals or humans increases the difficulty of evaluating risk, and limits the availability of common controls which are used for inanimate objects. This difficulty occurs because people or animals being handled can move on their own which may hinder those performing the handling. When people or animals move on their own, it may require the handlers to apply additional force to restrain the people or animals or to exert sudden force in response to unexpected movements.

4.8.4 The nature of the people or animals may place additional demands on the handlers or limit the way the handling is performed. Some examples are:

- (a) hospital patients require extreme care in handling, often while attached to fragile medical equipment; and
- (b) distressed people or animals may require restraint in addition to the force needed to move them.

4.8.5 Answering YES to any of the following indicates an increased risk:

- (a) Does the person or animal need to be moved in a special way?
- (b) Is the person or animal distressed, excited or moving vigorously?
- (c) Is the object awkward to carry?
- (d) Is the object difficult to grasp or hold?
- (e) Is the object unstable or unbalanced, or does it have contents that may move suddenly?
- (f) Is the object smooth, slippery, greasy or wet?
- (g) Does the object have sharp edges or protrusions?
- (h) Is the object very hot or cold?
- (i) Does the object block the view of the employee when being handled?

4.9 RISK FACTOR “H” - WORK ORGANIZATION

4.9.1 The way work is organized may affect risk. Risk may also be affected by combining the way work is organized with other risk factors such as staffing levels, availability of equipment, work schedules, shift work, work pace, task variety, work procedures, rest breaks and the time allowed for recovery between tasks (i.e., recovery time).

4.9.2 Answering YES to any of the following questions indicates an increased risk:

- (a) Is the work flow affected by delays, sudden changes or poor design in the flow of materials?
- (b) Are there **insufficient** numbers of employees to carry out the work within a deadline?
- (c) Are there **insufficient** numbers of employees to carry out the work during regular peak periods?
- (d) Is there a **lack of** team lifting, and/or is it **not** safely organized when required?
- (e) Is there a **lack of** an effective maintenance program for tools, buildings and equipment?
- (f) Are procedures for reporting and fixing unsafe tools and equipment or environmental conditions **inadequate**?
- (g) Is the workflow intermittent and uneven?
- (h) Is there a **lack of** effective purchasing, instruction and maintenance programs for tools and equipment?

4.10 RISK FACTOR “P” - WORK ENVIRONMENT

4.10.1 Factors in the work environment that influence risk include climate, noise, lighting, vibration, work space, floors and other surfaces underfoot.

4.10.2 Housekeeping and footwear influence the risk of slips, trips and falls while working.

4.10.3 Answering YES to any of the following questions indicates an increased risk:

- (a) Are the floors and surfaces underfoot **uneven** or **slippery**?
- (b) Is the workplace **untidy** with a **lack of** attention to housekeeping details?
- (c) Are there extremes of heat, cold, wind or humidity?
- (d) Are there high levels of fumes, dusts, gases, steams, mists, or vapours?
- (e) Is there excessive vibration?
- (f) Is there excessive noise?
- (g) Is the task performed in a restricted space?
- (h) Is the lighting perceived to be below adequate levels for the task at hand?

4.11 RISK FACTOR “J” - SKILLS AND EXPERIENCE

4.11.1 Employees should have the knowledge and ability required to perform tasks safely. A mismatch between people’s knowledge and ability can increase risk of injury.

4.11.2 Answering YES to any of the following questions indicates an increased risk:

- (a) Does the employee **lack** appropriate instruction in ergonomics risks or prevention techniques?
- (b) Does the employee **lack** appropriate instruction in recognizing risk and evaluating tasks?
- (c) Does the employee **lack** proper orientation for the job practices and safety requirements in the workplace?
- (d) Does the employee **lack** the experience needed to perform the skill level required for the task?
- (e) Does the physical demand of the task exceed the physical ability of the employee?

4.12 RISK FACTOR “K” - AGE

4.12.1 Because young workers under the age of 18 are inexperienced and are still developing physically, they are at greater risk than adult workers.

4.12.2 An increased level of care is needed in the evaluation of risk and the application of appropriate controls for young workers. As a guide, use the following rule: the younger the worker, the more care needs to be taken. Young workers may feel comfortable exerting forces which are actually unsafe which could lead to soft tissue injury.

4.12.3 For older workers, increasing age may be associated with decreasing physical ability and endurance. However, age alone is not sufficient for evaluating risk; for example, older workers may be able to compensate for any physical loss through their experience and skill at the task. All relevant risk factors need to be taken into account.

4.12.4 Answering YES to any of these questions indicates an increased risk:

- (a) Are any workers under the age of 18 years?
- (b) Do young workers start a new job without receiving adequate information about safe work practices?

4.13 RISK FACTOR “L” - WEARING APPAREL

4.13.1 The type of clothing an individual wears may hinder safe work practices: for example, tight clothing may restrict movements. When special clothing is required, such as uniform or personal protective equipment, it is important to evaluate the effect of these items on risk.

4.13.2 Answering YES to this question indicates an increased risk:

Is special clothing required which may restrict movement?

4.14 RISK FACTOR “M” - SPECIAL NEEDS

4.14.1 In some instances, employees may have special needs that require consideration in the risk evaluation process. These needs may be permanent or temporary: for example, returning to work from an illness or extended leave of absence, pregnancy, specific disability, etc.

4.15 RISK FACTOR “N” - OTHER FACTORS

4.15.1 Any other risk factors considered relevant by the employer, the employees, or their health and safety committee or worker health and safety representative.

4.16 FURTHER ADVICE ON RISK EVALUATION AND CONTROL

4.16.1 In some situations, further advice and guidance on evaluation of soft tissue injury risks and risk control may be helpful.

These may be situations such as:

- there is disagreement about the results of a risk evaluation
- significant costs may be involved in controlling risks
- more information is needed to prioritize risks
- more information is needed to choose between risk controls
- there is a need to assess the extent to which risks will be controlled by risk controls
- there is a need to assess the extent to which risks will be altered by workplace changes
- designing and setting up new jobs and tasks
- setting up new workstations and work area.

In these situations, advice and guidance may help resolve the situation.

4.16.2 In addition, other methods for evaluating risks and helping to determine risk controls may be helpful. When thinking about using any other methods, it is important to note that:

- the evaluation method described in this guideline should be done **before** using any other method
- most methods require the involvement of a competent person in their use or in the interpretation of their results
- some methods require specialized equipment
- the method should be appropriate to the task and provide the information required
- any costs of using the method (such as: time, equipment, consultants’ fees, interruption to work processes) should be outweighed by the benefits of the information obtained

5. RISK CONTROL

5.1 PRINCIPLES

5.1.1 Employers should consider ways and means of reducing risk by either eliminating or minimizing risk factors. The following methods for controlling risk are proposed:

- (a) re-engineering the operations, equipment or buildings to eliminate or reduce risk factors;
- (b) considering administrative controls where re-engineering is impractical;
- (c) ensuring new and current employees who are at risk of soft tissue injuries are instructed in risk recognition and evaluation;
- (d) ensuring that workers are instructed in the use of specific controls to prevent soft tissue injury such as: safe work procedures, mechanical aids, and protective equipment; and
- (e) using appropriate work related clothing or protective equipment, only as a final consideration.

5.1.2 Employees newly engaged in physically demanding tasks or processes or who are returning from an extended absence, should be allowed a period of adjustment to build up the skills and ability demanded by the tasks they are required to perform.

5.1.3 Risk control is the process of eliminating or reducing recognized and evaluated risk factors. It is likely that for many jobs a combination of controls may be needed. For example, in some cases it may be possible to re-engineer parts of equipment to partially eliminate the risk and where the risk cannot be eliminated, to provide mechanical aids.

5.1.4 Job or task redesign is the preferred risk control option. However, no one single option will necessarily reduce a risk by itself. Risk control can best be accomplished by a combination of control options which are listed below in descending order of effectiveness:

- (1) eliminating the task
- (2) redesigning the process and task
- (3) redesigning the work area
- (4) providing mechanical handling aids
- (5) providing instruction
- (6) environmental controls
- (7) developing other controls.

5.1.5 Study the problem (ergonomics risks) thoroughly before introducing controls so that new problems and risks are not created as a result of inadequate solutions.

5.1.6 To eliminate or reduce risks, you need to find the **sources of risk** for each of the risk factors evaluated using the Risk Evaluation Checklist. The sources of the risk need to be addressed. In finding the sources of risk, it may be helpful to refer to any sketches, photographs or comments about the task which were added to the risk recognition and evaluation checklists.

Ask yourself, your employees and health and safety representatives questions such as:

- What is causing employees to use awkward postures or movements (for example, the layout of the workplace, a workstation that cannot be adjusted, the position and type of objects being handled, poor housekeeping or bad lighting)?
- Why does such high force need to be used (for example, the heavy weight of the object being handled, or a tool with grips that are too large for most hands)?
- Why do employees have to do the task so often, or for so long (for example, the work pace is too fast due to tight deadlines, or staff numbers are limited)?
- What is causing exposure to heat, cold or vibration (for example, a task is done too close to a furnace while wearing protective clothing, or using a poorly maintained tool or equipment with inadequate vibration damping mechanisms)?

5.1.7 An overview of possible control factors follows, (i.e., Control Factors 1-6), in descending order of effectiveness. A combination of one or more of these may be effective at reducing risks.

5.2 CONTROL FACTOR #1 - ELIMINATING THE TASK

5.2.1 Is the task essential to the work process? If it is not deemed essential, then consider eliminating the task. If it is essential, then redesign the process and/or task.

5.2.2 In establishing whether the task is essential, ask the following questions:

- (a) Is the task necessary to complete the work assignment?
- (b) Is the task necessary for any other reason?

If “no” is the answer to **both questions**, then consider eliminating the task; otherwise, redesign the process and/or the task (Control Factor #2).

5.3 CONTROL FACTOR #2 - REDESIGNING THE PROCESS AND TASK

Modify Object

5.3.1 Objects being handled may be modified by reducing the weight or size or by changing the shape to make it less awkward to handle.

5.3.2 Where the presence of a risk factor has been recognized, the modifications suggested in the following questions may assist to reduce the risk:

- (a) Can the weight of the item be reduced?
- (b) Can the item be packaged in smaller containers?
- (c) Can the item be made less bulky so that it can be handled closer to the body?
- (d) Can the shape or surface texture of the item be changed to make it easier to grip?

- (e) Could the surface be cleaner or cooler, or the edges less sharp so the employee can hold the item against the body or without gloves?
- (f) Can handles be provided or some type of sling used to move the item?
- (g) Is the item designed or secured so it will not shift unexpectedly while being moved?

Modify Actions, Movements and Forces

5.3.3 Principles involved in minimizing the risk of injury when applying force include:

- (a) pushing/pulling is more efficient if applied at or around waist level;
- (b) pushing in/pulling out is stronger than pushing across the body (left/right);
- (c) for manual handling, significantly higher push/pull forces are possible when standing than when sitting. When standing, the body can better use its weight in pushing/pulling. This is why standing is preferred over sitting; and
- (d) avoiding awkward postures while exerting force reduces the risk of soft tissue injury.

5.3.4 With or without workplace modifications, a task may be done in a different way using different actions, movements and forces. Where risk factors have been recognized, the following suggestions may assist in reducing the risk.

5.3.5 Bending movements can be reduced by:

- (a) using lift tables, conveyors and similar mechanical aids;
- (b) raising the work level;
- (c) positioning all material at work level;
- (d) keeping materials at work level, for example, avoiding unnecessary lowering of items that will later be lifted; and
- (e) eliminating excessively forward reaches.

5.3.6 Twisting movements can be reduced by:

- (a) positioning all tools and materials in front of the employees;
- (b) using conveyors, chutes, slides or turntables to change the materials flow direction;
- (c) providing adjustable swivel chairs;
- (d) providing sufficient work space for the employee's whole body to turn; and
- (e) improving layout of the work station and/or area.

5.3.7 Reaching motions can be reduced by:

- (a) positioning tools and materials close to the employee;
- (b) enabling the item to be kept close to the body;
- (c) reducing size and shape of item being handled;
- (d) improving layout of work station and/or area.

5.3.8 Lifting and lowering forces can be reduced by:

- (a) eliminating the need to **manually** do the task by using: lift tables, mechanical lifts, cranes, hoists, balancers, drum and barrel dumpers, work dispensers, elevating conveyors and similar aids; and by raising the work level, lowering the position of the employee and by using gravity dumps and chutes;
- (b) reducing item weight by: reducing load size (for example, when ordering photocopying paper, specify the packaging requirements to suppliers), reducing the amount containers can hold, reducing the weight of the container, reducing the load in each container, and reducing the number of items lifted or lowered at one time;
- (c) grouping items so that they can be handled collectively by mechanical means (eg. placing several items on a fork lift pallet for transfer);
- (d) holding the item close to the body. This can be achieved by making the shape of items/containers easy to hold, providing suitable grips or handles, providing greater access to the load and by improving workplace layout; and
- (e) changing lifting and lowering actions to pushing or pulling forces.

5.3.9 Pushing and pulling forces can be reduced by:

- (a) using powered conveyors, powered trucks or movers and slides, rollers or chutes;
- (b) reducing load weight by:
 - using non-powered conveyors, carts, monorails and similar aids;
 - using four-wheel hand trucks, hand trolleys with large diameter wheels or castors appropriate to the particular surfaces;
 - providing good maintenance of equipment and floor surfaces;
 - using mechanical pushers or pullers; and
- (c) reducing the distance to be travelled by improving work area layout, relocating production or storage area, or making a similar system change.

5.3.10 Carrying forces can be reduced by:

- (a) converting to pushing or pulling by using conveyors, carts, monorails, slides, chutes, mechanical lifts, two or four-wheel trucks, trolleys or any other similar aids;
- (b) reducing the weight and size of the item, reducing the capacity and weight of the containers, reducing the amount put in each container, and reducing the number of objects carried at one time; and
- (c) reducing the distance items/containers are carried or transported by improving work area layout, relocating storage or production area, or making similar system changes.

5.3.11 Holding forces can be reduced by:

- (a) reducing item/container weight;
- (b) reducing item/container size;
- (c) reducing holding time; and
- (d) using mechanical aids.

Modify Task - Mechanical Assistance

5.3.12 The risk associated with a task can be reduced by mechanical assistance, minor rearrangement of equipment and an effective maintenance program.

5.3.13 Is there mechanical assistance which would be suitable for the work layout and task performed? Examples of such mechanical aids include, but are not limited to, the following: hooks, platforms, bars, trestles, rollers, conveyors, jacks, dumpers, fork lifts, wheelbarrows, and patient lifts.

5.3.14 The following figures (6 & 7) are examples of the use of mechanical assistance.

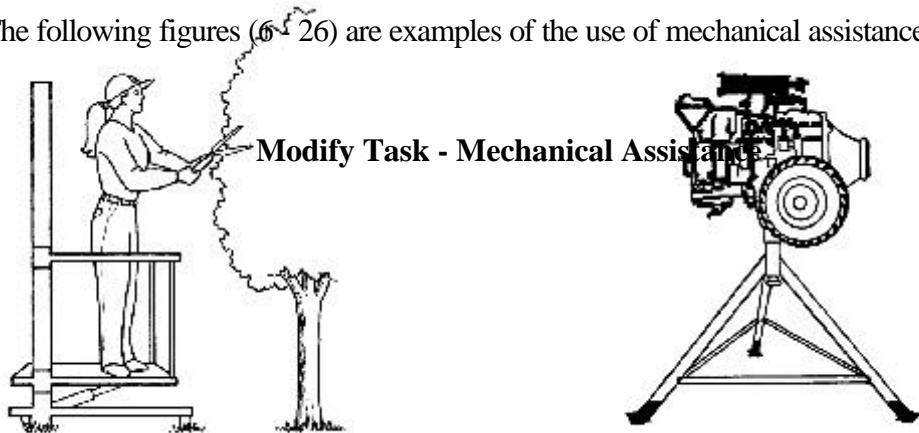

Figure 6 - Adjustable platform reduces stooping and reaching

Figure 7 - Stand to avoid awkward posture



Figure 8 - A simple trolley avoids awkward handling.

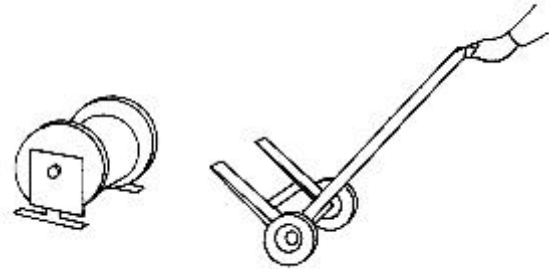

Figure 9 - A simple lever and wheels avoids stooping and reduces effort.

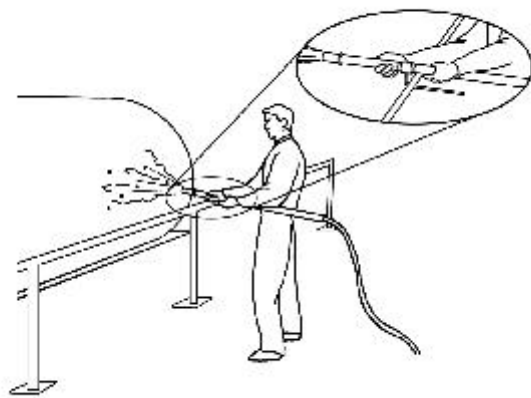
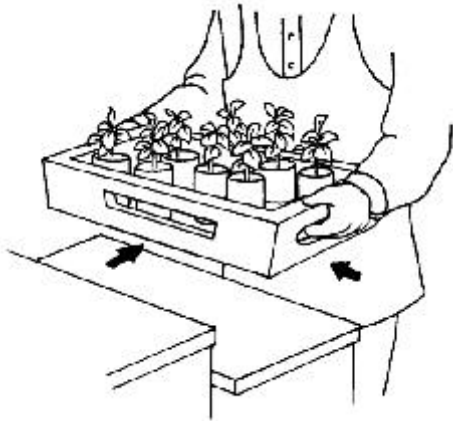
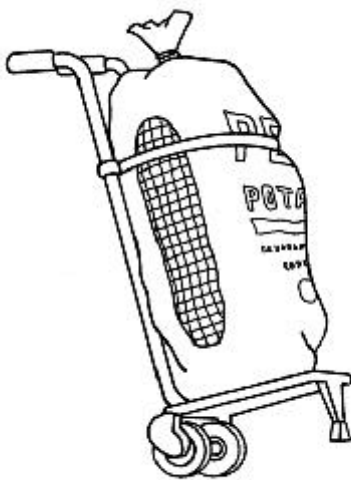
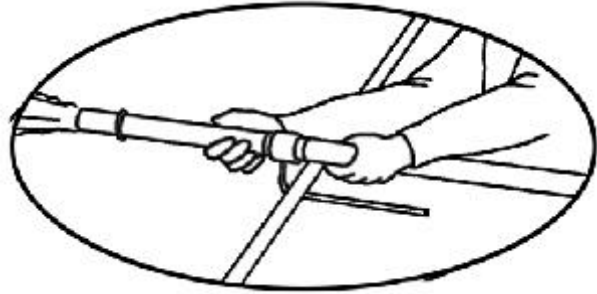

Figure 10 - Design for finger space.



Figure 11 - Use structures to absorb reaction forces.



ter

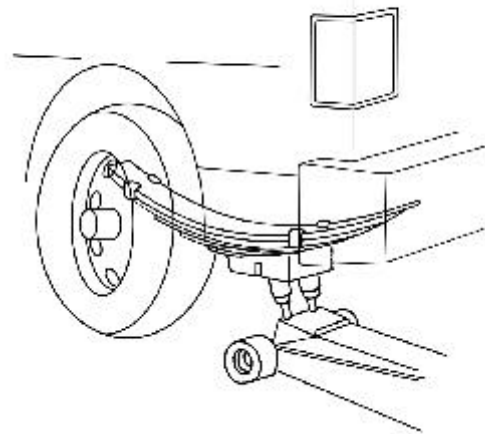
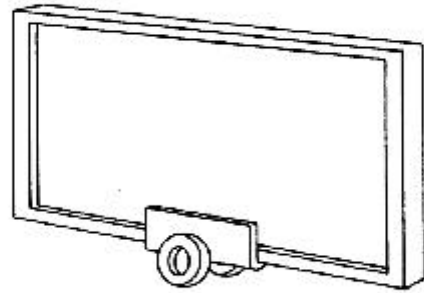
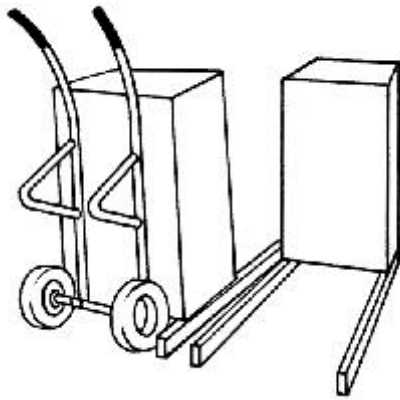
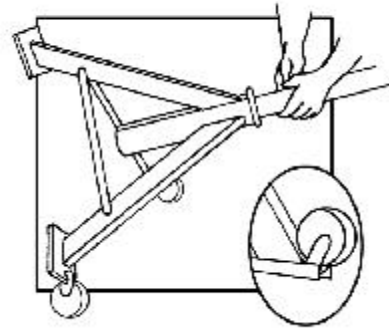
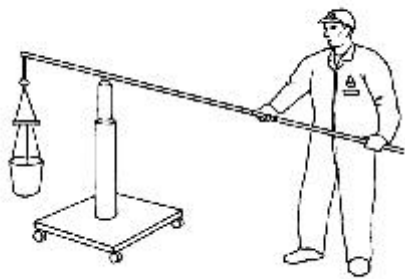

Figure 14 - Hand Trolley.

Figure 15 - Support weight by use of jack.



-----le



In use

Figure 18 - Lever and rolling platform reduces effort.

Figure 19 - Wheels enable pushing in place of carrying.

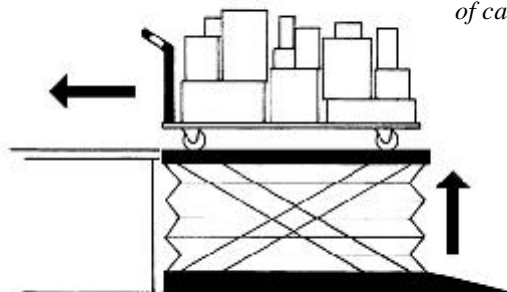

Figure 20 - Adjustable height platform reduces lifting.

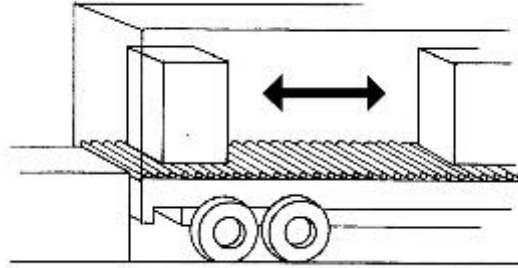
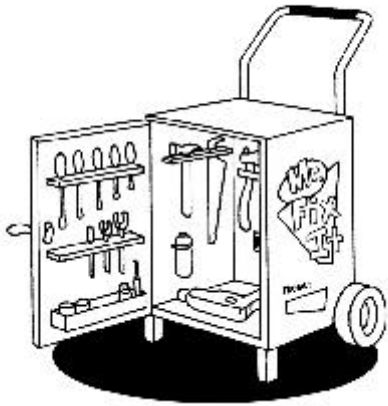

Figure 21 - Custom made trolley avoids carrying.



Figure 22 - Floor rollers assist moving..

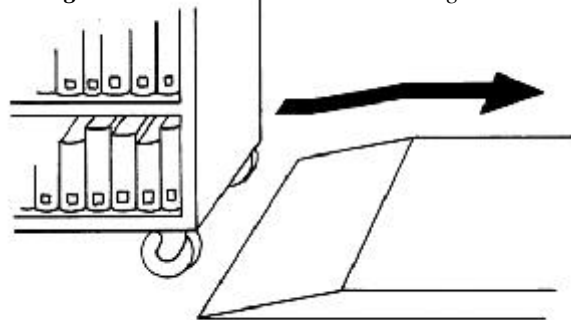

Figure 24 - Ramps avoid lifting or dragging.

Figure 23 - Levers reduce force required.

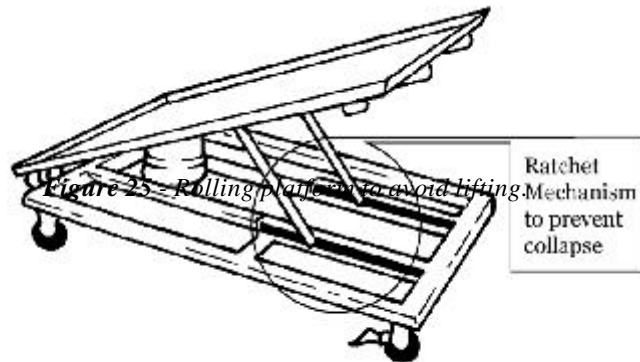
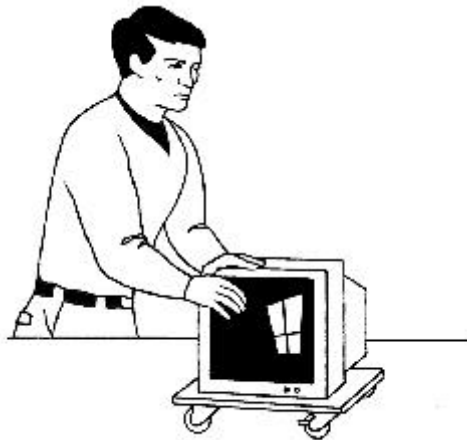

Figure 26 - Rolling platform with tilt mechanism.

Modify Task - Team Lifting

5.3.15 The actions, movements and forces required for materials handling can be modified by using team lifting methods.

5.3.16 Team lifting may be effective in reducing risk in certain handling tasks; however, the regular need for team lifting usually signals the need for redesign of the task.

5.3.17 Whenever team lifting is used, it is essential to co-ordinate and carefully plan the lift. In organizing a lift, it is important to ensure:

- (a) an adequate number of persons in the team;
- (b) one person is appointed to coordinate the lift;
- (c) the team members are of similar physical ability and know their responsibilities during the lift;
- (d) appropriate instruction in lifting has been provided; and
- (e) the lift has been rehearsed, including what to do in case of emergency.

5.4 CONTROL FACTOR #3 - REDESIGNING THE WORK AREA

Modify Workplace Layout

5.4.1 The layout of the building, equipment, tools and supplies may be modified or rearranged to improve accessibility and housekeeping.

5.4.2 The layout of the workstation, building and equipment in the workplace may place the employees at an increased risk of injury. The layout of the workplace should be appropriate for the task and matched to the employee. The employee should be able to perform the task without undue difficulty.

5.4.3 When work heights are too low or too high, employees may be forced to adopt inappropriate and awkward body positions. Displays may be placed where they cannot be reached or easily seen. Frequently used controls, tools and materials may be placed beyond easy reach. Such workstation layouts may result in employees using inappropriate positions, such as bending to one side, bending forward, reaching overhead or twisting the body, which increases the risk of injury. There is even greater risk if awkward postures are maintained for long periods of time.

5.4.4 The following figures are examples of modified workplace layouts:

Modify Workplace Layout



Figure 27 - Store heavier and frequently used items at waist level.



Figure 28 - Raise work level by use of self-adjusting platform.

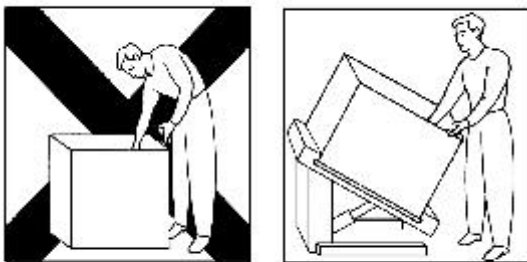

Before

After

Figure 29 - Prevent excessive bending of the back by adjusting work level.

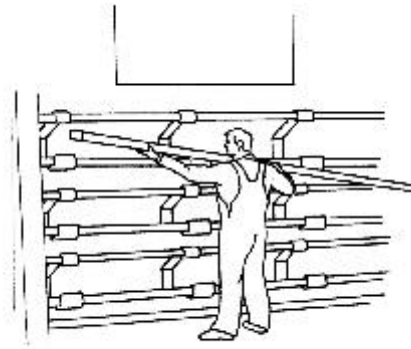
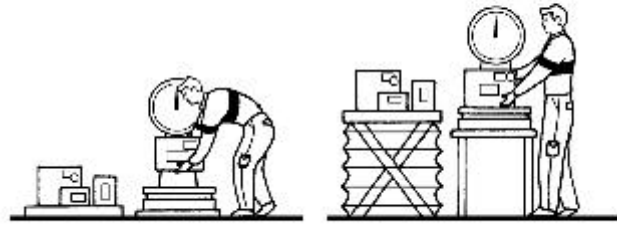
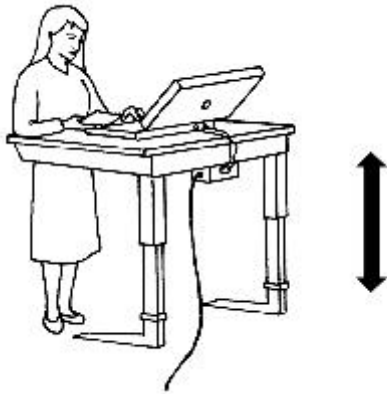

Figure 30 - Adjustable storage heights



Poor

Better

Figure 31 - Adjustable work heights.

Figure 32 - Adjustable work heights

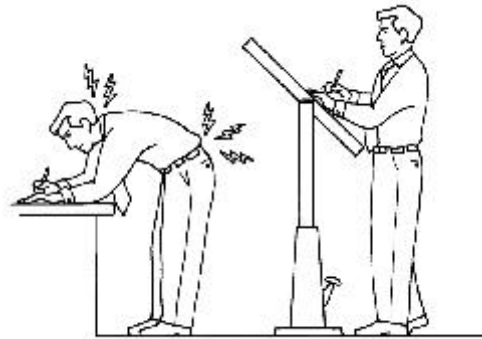
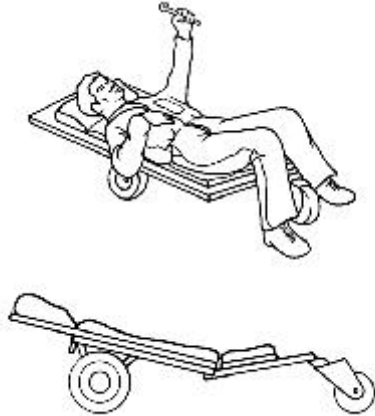

Before

After

Figure 33 - Avoid muscle fatigue when working in awkward positions.

Figure 34 - Improve Posture.

Tools Design and Modification

5.4.5 The design of tools, devices and controls has an influence on work posture, movements and physical stress. Some principles of good design are:

- (a) Tools are as light as possible.
- (b) Heavy tools are fitted with devices, such as balancers, to save the employee from having to support an unnecessary weight and are designed for two-handed use.

Tools can be suspended from balancers or tool supports to reduce the force needed to use them and the fatigue resulting from their repetitive and sustained use.

Well-designed balancers and tool supports counteract the effect of gravity, reduce the effort of holding or supporting the tool, and minimize sudden twisting forces on the hand and arm from the action of the tool. They also reduce the length of time the tool needs to be held.

Mounting the tool, for example, in a drill stand - will eliminate or reduce the need to hold the tool for long periods.

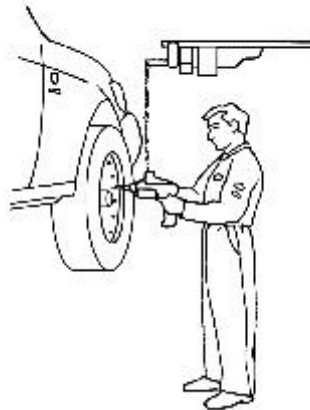

Figure 35 - Suspended tools avoid unnecessary load.

- (c) Tools are well balanced. The angle between handle and working parts is designed to avoid unnatural bending of the hands and arms.
- (d) The handle is designed to suit the grip and force required. Preferably, it is designed in such a way that the user can change grip.
- (e) The grip surface does not conduct heat or cold easily. It is sufficiently rough to prevent hands from slipping and has no sharp or protruding parts to cause injury or pressure on the hand.
- (f) Tools are provided with adequate insulation from vibration, if necessary.

- (g) Tools are suitable for both right-handed and left-handed employees and for hands of different sizes.
- (h) Tools do not require constant trigger operation, but have an on/off function.

Controls Design

- 5.4.6** Hand controls are often preferable for precision or speed of operation, while foot controls are generally best if greater force has to be applied. Pedals are most conveniently and safely operated from a seated position. The pedal should be designed and positioned in such a way that the employee can support the heel of the foot on the pedal or on the floor. This will make it easier to maintain balance if standing.
- 5.4.7** Controls or levers should require forward and backward forces as opposed to push or pull forces across the body.
- 5.4.8** The appropriate design, selection, arrangement and labelling of displays and control instruments are essential for safe operation of equipment and will assist in correct posture.
- 5.4.9** A sensible layout of both displays and control instruments will make monitoring easier, reduce the risk of confusion caused by misreading and reduce visual and postural strain.
- 5.4.10** Consider the following:
 - (a) Are controls and displays conveniently located for the operator?
 - (b) Are controls easily distinguished (eg. size, colour and shape)?
 - (c) Are controls located near the display?
 - (d) Can displays be easily seen in the work environment?
 - (e) Are human physical factors taken into account regarding the distance between control instruments? The size of knobs, switches or control instruments should relate to whether they are operated by fingers or the whole hand.

Rearrange Material Flow

- 5.4.11** The risk of soft tissue injury may be reduced by the modification of the schedule, timing and/or path of materials flow.

5.4.12 Where the presence of risk factors has been recognized, then the following actions may reduce the risk:

- (a) Rearranging the containers and the way materials are moved around the workplace and between different parts of the work process.
- (b) Placing loads to be handled in an optimum location. The best height range for handling loads is around waist level with lifting between the knuckle and the shoulder being acceptable.
- (c) Scheduling of materials flow to avoid unnecessary repetitive motions or fast paced work.
- (d) Using mechanical devices to reduce the force involved in materials flow. See examples below:

Rearrange Material Flow

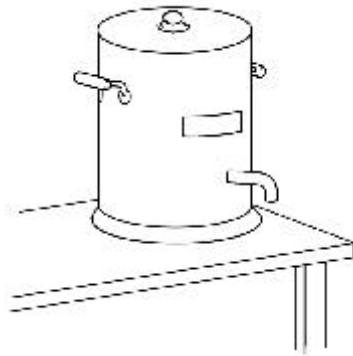

Figure 36 - A tap avoids lifting to pour contents

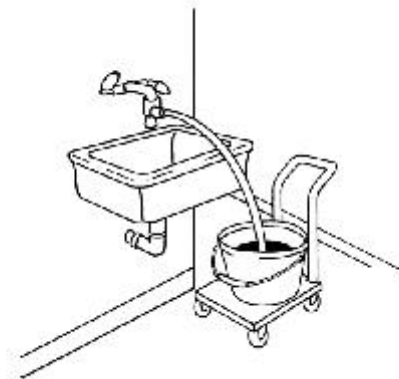

Figure 37 - A hose avoids lifting

5.5 CONTROL FACTOR #4 - PROVIDING MECHANICAL HANDLING AIDS

5.5.1 Mechanical handling aids and appropriate instruction can reduce risks by decreasing the forces required.

5.5.2 Mechanical handling aids include:

- (a) simple aids, for example: levers, handles, winches, chutes, sliding rails, belt conveyors and roller conveyors;
- (b) cranes and hoists, for example: overhead travelling cranes, mobile hoists and patient lifts;
- (c) positioning equipment, for example: scissors jacks, waist belts, tilting mechanisms;
- (d) wheeled carts, for example: trolleys, dollies and utility carts; and
- (e) industrial vehicles, for example, fork lift trucks and two-wheeled hand trucks.

5.5.3 Mechanical handling aids should be:

- (a) easy to use and not cause an obstruction;
- (b) designed to suit the load;
- (c) readily available even in emergencies; and
- (d) regularly maintained.

5.5.4 Operators should be provided with information, instruction, and supervision in the use of mechanical aids and opportunities for hands-on experience.

5.5.5 The design, installation and use of mechanical handling aids may be subject to provincial legislation.

5.5.6 Illustrations of mechanical handling equipment follow.

Mechanical Handling Equipment

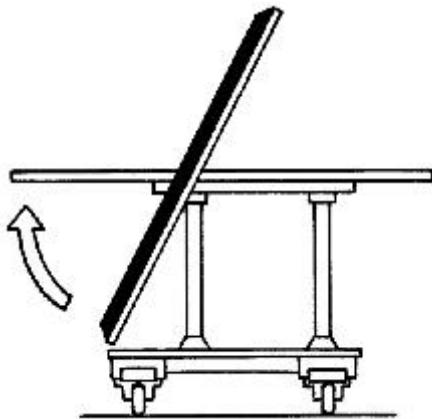

Figure 38 - A transport wagon designed for handling sheets of material.

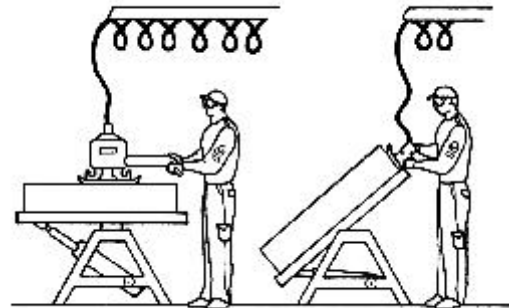

Figure 39 - An adjustable support stage provides a better work position for finishing surfaces.

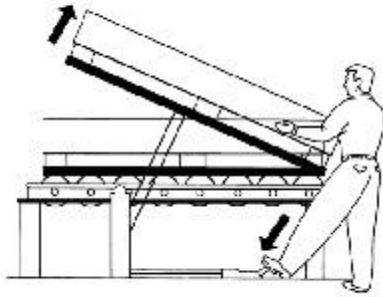

Figure 40 - Hydraulic tilt bed.

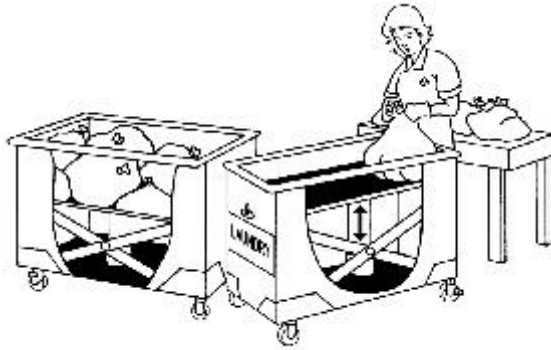

Figure 41 - Adjustable scissor table for different work heights.

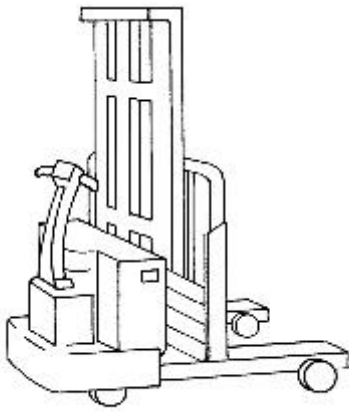

Figure 42 - Electric Jack

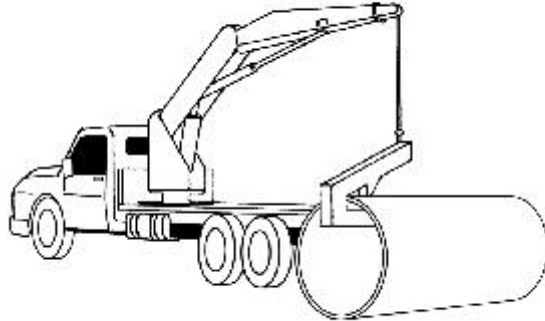

Figure 43 - Using C-hook to move cylinders and pipes.

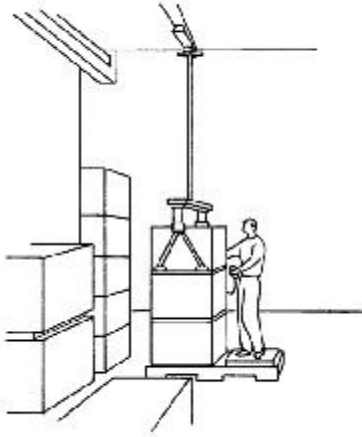

Figure 44 - Electric Hoist

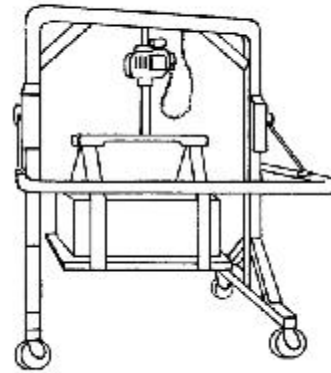

Figure 45 - Gantry crane for lifting heavy material off pallets.

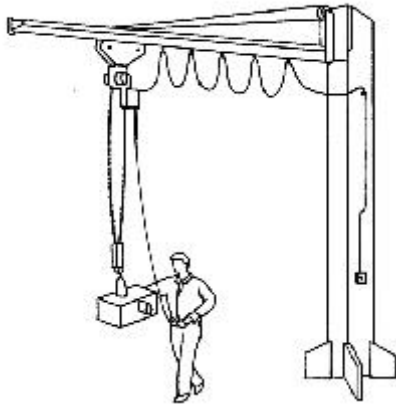

Figure 46 - Overhead crane for heavy lifting.

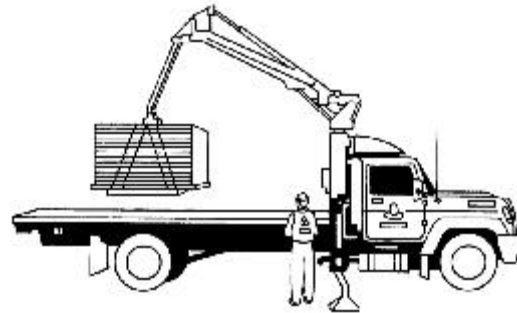

Figure 47 - Mobile Crane

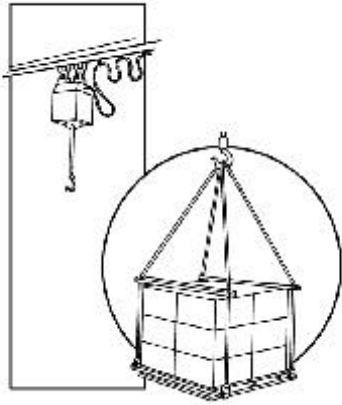

Figure 48 - Specially designed hooks or slings for lifting

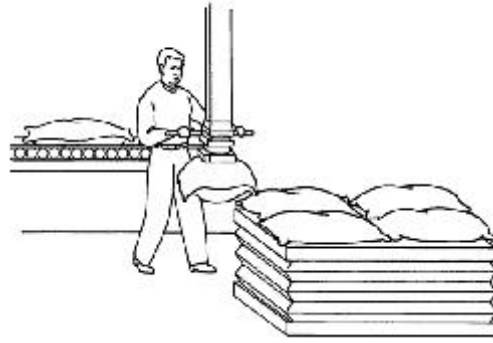

Figure 49 - Vacuum lifter for material handling

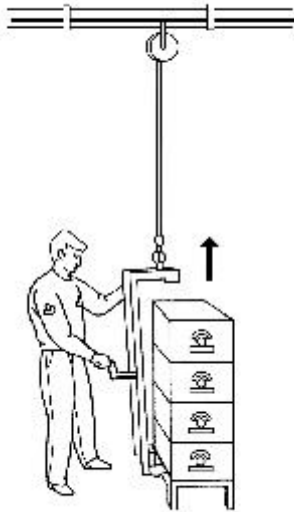

Figure 50 - Lifting device for moving boxes and crates.

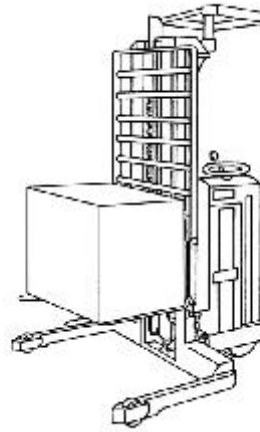
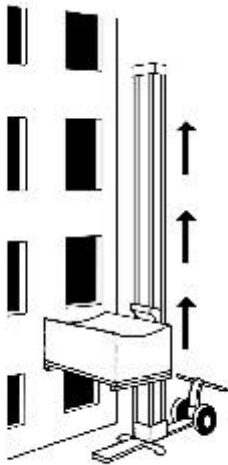

Figure 51 - A lifting cart makes it easier to lift and transfer materials to store at shoulder height.



5.5.7 Where the previous options have been unable to significantly reduce risk, a worker may require instruction, training and/or education in safe work procedures for that particular physical task.

5.6 CONTROL FACTOR #5 - PROVIDING INSTRUCTION

5.6.1 The principles dealing with general instruction are outlined in Section 2.4 of this Guideline.

Task Specific Instruction

5.6.2 Where a risk has been evaluated:

- (a) The employer should ensure that the evaluated risk is controlled by re-engineering the operations, equipment or buildings to eliminate or reduce the risk factor;
- (b) The employer should ensure that a worker, who is assigned to work which requires specific measures to control the risks of soft tissue injuries, is instructed in the use of those measures, including safe work procedures, mechanical aids and protective equipment.

5.6.3 Task specific instruction should take place once an analysis of the task(s) has recognized the risk factors present. Once the analysis has eliminated the option of modifying work design, the safest work procedure should be defined and should form the basis of the task specific instruction. The instruction program should be tailored to meet the specific tasks being performed by the target group.

5.6.4 The instruction must be specific to the task and should aim to ensure that the employee:

- (a) understands the reasons for doing the job with least risk;
- (b) can recognize the risks and decide the best way to go about it;
- (c) knows what is the best way to go about it; and
- (d) can perform the task in the best way.

5.6.5 This instruction should be supplemented by appropriate supervision when required. Any instruction which is provided for employees performing physical tasks should also be provided to their supervisors.

5.6.6 ~~The employer, in conjunction with employees and/or employee representatives, should regularly review instruction programs to ensure instruction objectives are met.~~ *Figure 5B. Mechanical aids for patient lifting and moving.*

5.6.7 Instruction should also be reviewed when there is:

- (a) a change in work practices including risk controls;
- (b) a change in workplace layouts, task design or organization; and
- (c) an introduction of new or modified buildings, tools, supplies or equipment.

5.6.8 As part of the job orientation, instruction should be provided for all new employees and supervisors as well as workers returning from extended leave.

5.6.9 Refresher instruction should be provided on a regular basis to ensure maintenance of safe work practices.

5.6.10 Employees should, where able:

- (a) participate in and use the instruction provided in safe procedures and practices;
- (b) participate in and use the instruction provided in specific tasks, skills and techniques;
- (c) use the mechanical aids or devices and the associated instruction provided;
- (d) take any rest breaks provided;
- (e) cooperate with their employer in recognizing any risks; and
- (f) report to their immediate supervisor or employee representative any problems observed or experienced with tasks involving repetitive or forceful movement or both, and/or prolonged awkward postures.

Instruction in the Principles of Manual Handling and Computer Workstation Setup

Manual Handling

5.6.11 For purposes of instruction programs, the following principles apply for most manual handling tasks.

Plan

5.6.12 As one way of avoiding soft tissue injuries, the employee undertaking the manual handling should test the weight of the load, determine where it will be placed and decide how it will be handled. By first evaluating the situation, the employee can decide if mechanical assistance/aids or another person is needed to move the object, animal or person safely.

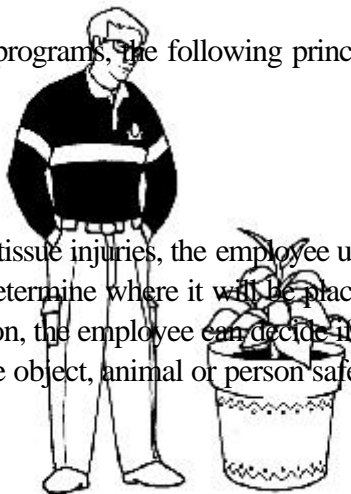

Determine the Best Technique

5.6.13 All factors should be taken into account when determining the best technique. The best handling technique involves suitable balance and avoiding unnecessary bending, twisting and reaching. A person undertaking a lift should lift efficiently and rhythmically, minimizing bending of the lower back. The knees should be bent, but preferably not at a right angle. When applying force, the principles in sections 5.3.3 - 5.3.11 of this guideline are also relevant.

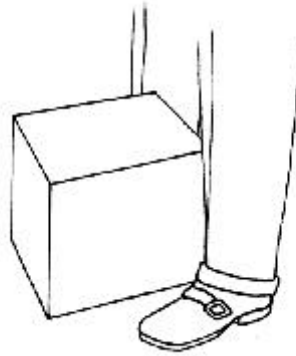

Figure 55 - Determine the best lifting technique.

Housekeeping

5.6.14 In order to transport the load safely, the route should be clear of obstruction and well lit.

- (a) Ensure that there is a clear route to take by removing unnecessary objects or debris, and ensuring good housekeeping in and around the work area in order to avoid slips, trips, and falls;
- (b) Use floor markers or pointers and overhead signs to direct traffic flow where required; and
- (c) Use mirrors and other visual aids to help workers manoeuvre safely around corners and other obstacles.

Take Secure Grip on the Object Being Handled

5.6.15 The grip helps to determine how safe the task will be. Whenever possible, a comfortable power grip (with the whole hand) should be used rather than a hook or precision grip (with fingers only). Using gloves can reduce grip strength. Using handles where possible is recommended.

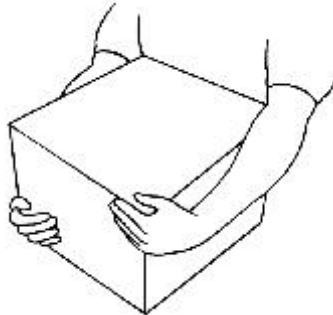

Figure 56 - Get a secure grip.

Pull the Load in Close to the Body

5.6.16 For lifting in particular, it is important to have the centre of gravity of the load close to the body to prevent excessive stress on the back and to use the strongest muscles of the arms to hold the load. It is important to minimize the effects of acceleration by lifting slowly, smoothly and without jerking.

There should be sufficient space for lifting to be done in the right position and with correct posture and body movements.

The centre of gravity of the load should be as close to the body as possible. A load is more difficult (heavier) to lift or carry if it is not close to the body. For example: 4 kg held at a distance of 60 cm imposes the same load as 12 kg held right to the body.

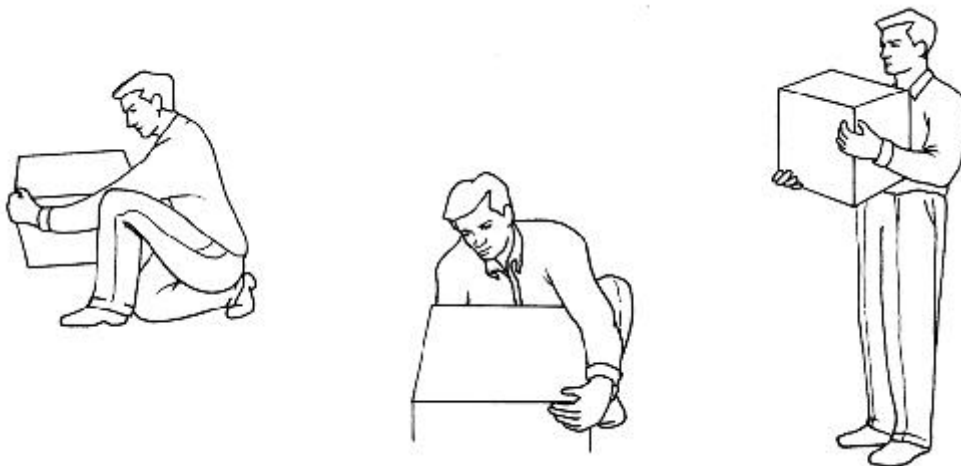

Figure 57 - Pull the load in close.

Lift Considerations

5.6.17 It is difficult to generalize about the optimum or maximum weight of a load to be lifted, because there are so many factors involved besides the actual weight to be lifted. However, the following points should be considered:

- (a) The start and finish height of the load should be at a suitable level above the floor; that is, between mid-thigh to shoulder height, preferably at the waist height.
- (b) The back should not be twisted or bent sideways.
- (c) Lifting with one hand should be avoided.
- (d) If lifting has to be performed frequently or for long time periods, then the weight of the load should be decreased.

Alternate Between Heavy Handling Tasks and Light Work

5.6.18 The job/task should be designed so as to provide alternative tasks that do not heavily stress the same muscles. Throughout the work shift, heavier handling tasks should be alternated with lighter tasks which allow the active muscles to recover.

Team Lifting

5.6.19 To enable load sharing, lifting partners should be of similar height and build and should be instructed in lifting techniques. There should be a person nominated as team leader to coordinate the lift. Mechanical lifting aids should be used if possible, as team lifting should not be used as a first option in risk control.

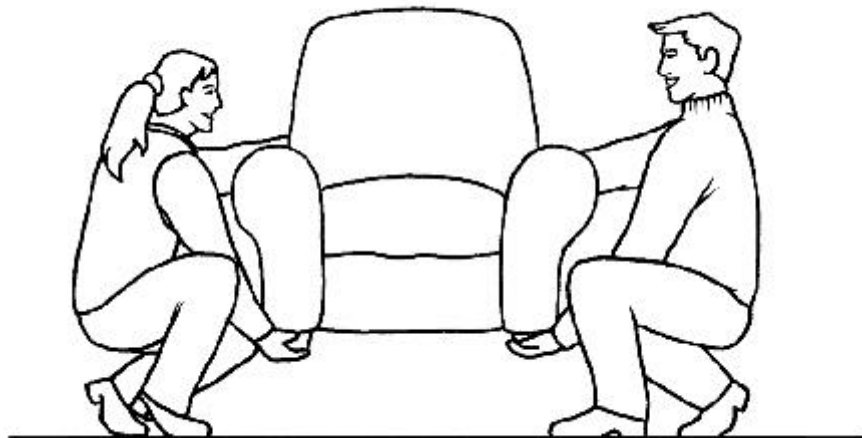

Figure 58 - Team lifting

Computer Workstation Setup

5.6.20 For the purposes of instruction programs the following principles should apply for computer workstation setup.

Check Your Posture

5.6.21 When using your computer, you should be able to sit with your:

- (a) forearms held horizontally at about 90-degrees or right angle at the elbow, with shoulders and upper arms relaxed;
- (b) wrists in a neutral (straight) posture;
- (c) head upright over your shoulders in a relaxed position, with your eyes looking slightly downward;
- (d) backrest supporting your lower back, pelvis and the natural curve of your spine;
- (e) thighs resting horizontally at approximately 90 to 100 degrees angle at the hips; and
- (f) feet fully supported by the floor or a footrest, with approximately 90-degrees or right angle at the ankles.



Figure 59 - Adjusting Your VDT Workstation.

Chair Adjustment

5.6.22 There are a number of reasons why you should adjust your chair:

- (a) Seating that doesn't adequately support your back increases fatigue and contributes to poor posture.
- (b) Seating that is too high can result in awkward neck postures or pressure on the back of the thighs.
- (c) Seating that is too low may require you to: use awkward arm postures to reach up to the work surface, rest your arms against the sharp edge of the desk, and/or to sit with your knees raised, increasing the stress on your lower back.
- (d) Sitting for long periods without varying your posture decreases circulation.
- (e) Ensure that you know and understand the adjustment features of the chair and use them as needed.

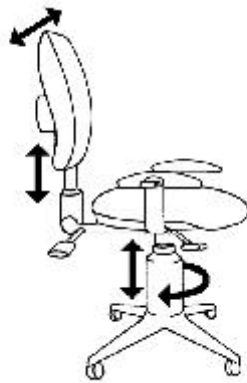

Figure 60 - Chairs should be easily adjustable in respect to (i) seat height (ii) backrest height and (iii) backrest angle

Make your Computer Workstation Layout Fit You

5.6.23 Your computer workstation should be arranged so that you can use comfortable postures when working with the monitor, keyboard, mouse, documents and other items.

If you have other tasks to perform (for example: writing or calculator use), ensure that the workstation has appropriate space available.

If your screen is at the correct height and viewing distance, it will help prevent or reduce eyestrain and muscle tension in your neck, shoulders and upper back.

Consideration should also be given to the following principles:

- (a) The top line of text on your computer screen (not the top of the terminal) should be just below eye level.
- (b) The distance between your eyes and the screen should be about arm's length.
- (c) If you wear bifocals, lower your screen so that you can hold your neck in a more comfortable posture.
- (d) Adjust your keyboard surface up or down so that your wrists are straight when your fingers are on the middle row of keys.
- (e) If your keyboard surface doesn't adjust this way, raise or lower your chair until you can hold your wrists straight, while touching the middle row of keys. Remember, your work surface should be just below your elbows, with your forearms parallel to the floor.



Figure 61
A palm or wrist support - like the one shown here - can support your palms during rest periods from keying. Make sure you

- (f) You can also make a slight adjustment to the keyboard angle and height by folding the small legs - on the underside of most keyboards - in or out.
- (g) Keep your mouse at the same height and as close to your keyboard as practical.
- (h) Rest your arm on your work surface to support the weight of the arm and reduce the risk of shoulder problems.
- (i) Ensure you are not resting your arms against the sharp edge of your desk.
- (j) Don't hold your mouse too tightly. Relax your hand over the mouse.

keybo
found

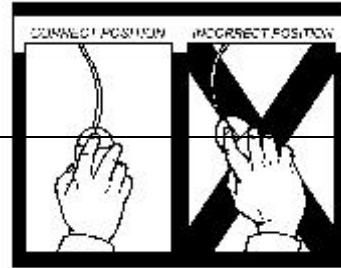

Figure 62

Keep your wrist straight during mouse work. Don't bend your wrist from side to side. Try to move your whole arm instead.

Organization and Storage

5.6.24 Place items that you use frequently or long periods within your immediate reach or primary work zone. Place items that you use occasionally or for short periods of time just beyond immediate reach or in the secondary work zone.

f o r
r e a
t h a t
p e r i

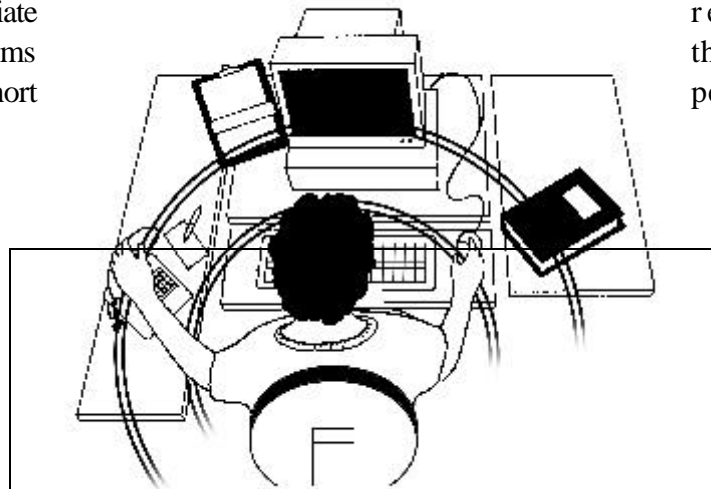

Figure 63

Primary and secondary work zones. Place items that you use frequently in the primary zone and items that you use occasionally, or for short periods of time, in the secondary

- (a) If you are reading from documents, use a document holder and place it as close as possible and at the same height and viewing distance as the screen.



Figure 64 - Poor placement of documents while keyboarding can lead to awkward postures.

- (b) If you often cradle the phone between your ear and shoulder, change to using a headset or speaker phone to avoid awkward neck postures.
- (c) Workstation storage areas include overhead cupboards, book shelves, and desk drawers. Do not place frequently used items in the storage areas.

Lighting considerations

5.6.25

- (a) To avoid glare from windows, position your computer workstation so that when you face the monitor, you are sitting beside or parallel to the window.
- (b) Close window blinds as necessary to reduce glare.
- (c) When light levels are low, illuminate the hard copy you are working from at the computer if you are having difficulty reading it.

5.7 CONTROL FACTOR #6 - ENVIRONMENTAL CONTROLS

5.7.1 Environmental conditions include vibration, heat and cold, and other factors such as lighting and housekeeping. Altering these conditions can help eliminate or reduce soft tissue injury.

Vibration

5.7.2 To eliminate or reduce exposure to vibration:

- (a) adjust any existing vibration damping mechanisms in mobile equipment;
- (b) install a vibration isolating seat in equipment such as cranes or tractors;
- (c) replace or modify powered hand-tools that expose employees to hand-arm vibration;
- (d) when purchasing equipment choose items which operate with minimum vibration; and
- (e) make sure that equipment and tools are serviced regularly.

If the vibration itself cannot be eliminated or reduced, minimize workers' exposure by decreasing the time spent using vibrating equipment and tools. Use job rotation, or do the task in a different way that reduces vibration exposure. If exposure can't be reduced, it's better if it occurs intermittently during a shift rather than in one continual block. Work related clothing, such as anti-vibration gloves, may be required.

Working in Heat and Cold

5.7.3 For employees working in hot conditions:

- (a) increase worker awareness of heat stress so that symptoms can be recognized;
- (b) reduce temperature and humidity where possible, by providing fans, ventilation, exhaust systems, or air conditioning;
- (c) use screens, awnings, and appropriate clothing to shield employees from radiant heat sources such as ovens, furnaces and the sun;
- (d) relocate work away from sources of heat;
- (e) enclose hot processes and increase ventilation to get rid of steam and hot air;
- (f) alter work schedules so that work is done at cooler times;
- (g) provide opportunities for employees who are not used to working in hot conditions to acclimatize;
- (h) provide a cool, well-ventilated area where employees can take rest breaks;
- (i) ensure that employees work at a reasonable pace;
- (j) provide a supply of cool drinking water and encourage employees to drink some regularly; and
- (k) workers should wear clothing, that is loose fitting and has light colors.

For employees working in cold conditions:

- (a) increase worker awareness of the warning signs of cold stress;
- (b) make sure that employees take regular rest breaks in a warm place;
- (c) ensure that employees wear appropriate clothing which is not too bulky or restrictive;
- (d) ensure that employees wear appropriate work related clothing (for example, gloves should provide adequate protection from the cold yet allow good grip of the objects being handled);
- (e) ensure that employees wear non-slip footwear; and
- (f) ensure that floors are not slippery.

Lighting

5.7.4 Poor lighting can make employees adopt awkward postures and movements in order to do their work. For example, to see scratches and other imperfections on painted panels, an employee must bend down and twist his or her head to look at the panels side-on.

To improve lighting and visibility:

- (a) provide additional lighting, such as a lamp on a movable arm;
- (b) improve the layout of existing lights by lowering or raising them or changing their position in the work area;

- (c) increase or decrease the number of lights;
- (d) change the diffusers or reflectors on existing lights;
- (e) change the lights to improve light levels or improve colour perception;
- (f) change what is being looked at - for example, bring it closer to the eye, or change its orientation or position to avoid shadows, glare or reflections;
- (g) clean lights and light fittings regularly; and
- (h) use screens, visors, shields, hoods, curtains, blinds or external louvres to reduce reflections, shadows and glare.

The eyesight of employees also needs to be considered. It is important that employees wear glasses if they need to, and that they have the right glasses for their work.

Housekeeping

5.7.5 Good housekeeping practices in the workplace improve productivity and reduce the risk of slips, trips and falls, thereby minimizing the potential for soft tissue injury.

5.8 CONTROL FACTOR #7 - DEVELOPING OTHER CONTROLS

Special Needs

5.8.1 Health and age should be taken into consideration when allocating duties, drawing upon medical advice as appropriate. As an individual's health changes, it may affect his/her capacity to perform normal duties. Changes may be permanent or temporary; therefore, the workplace and work practices should be adapted to suit the new circumstances or the individual should be allocated other tasks.

5.8.2 The increased experience and skills of older workers may compensate substantially for decline in the resilience of their tissues, including ligaments and joints.

Work Related Clothing

5.8.3 In some situations, special clothing is required to reduce risk of injury. The following examples demonstrate how special clothing can be used:

- (a) gloves provide protection for a variety of physical tasks; however, gloves can limit grip strength;
- (b) proper footwear assists prevention of injuries from slips and falls, and from dropped loads; and
- (c) proper clothing allows loads to be carried close to the body.

Scientific studies have not been able to confirm whether backbelts or similar devices can eliminate or reduce risks.

Such devices, therefore, are not considered to be valid risk controls. Sometimes, however, these devices are prescribed by health professionals for their patients, for limited use.

Incentive and Bonus Schemes

5.8.4 Incentive and bonus schemes have the potential to create risks by increasing the frequency and duration of manual handling tasks. Employees may need to work faster and for longer periods without breaks in order to meet targets. In order to control the risk, alter the work rate to reduce how often or for how long a task is done.

Work Organization

5.8.5 Risk may be controlled by reorganizing work elements such as: staffing levels, availability of equipment, work schedules, shift work, work pace, task variety, work procedures, rest breaks and the time allowed for recovery between tasks.

5.8.6 Set realistic work rates: allow for the physical demands of the task, differences between employees, and variation over time. Employees should not have to work at a rate that is at the limit of their capacity.

5.8.7 Try to organize the flow of work so that overload during peak periods is avoided. Where possible use alternatives to machine pacing, such as buffer systems. Examples of buffer systems include:

- (a) diverting items from a production line that is moving faster than the employee's comfortable rate, for the employee to process later; or
- (b) locating items near the employee, to be processed when the production has slowed or stopped.

If machine-paced work cannot be avoided, provide your employees with adequate breaks or other tasks that allow for a change of pace and posture.

Any Other Administrative Controls

5.8.8 Any other relevant factors should be taken into consideration when developing administrative controls.

REFERENCED DOCUMENTS

1. National Occupational Health and Safety Commission, “National Standard for Manual Handling” and National Code of Practice for Manual Handling (NOHSC: 2005 (1990)), Australian Government Publishing Service, Canberra, 1990.
2. National Occupational Health and Safety Commission, Code of Practice for the Prevention of Occupational Overuse Syndrome (NOHSC: 2013, (1994)), Australian Government Publishing Service, Canberra, 1994.
3. Workers Compensation Board of British Columbia, “How to Make Your Workstation Fit You”, (ISBN: 0-7716-2956-0), British Columbia, Canada
4. Workplace Health, Safety and Compensation Commission of New Brunswick, “Manual Handling”, New Brunswick, Canada.
5. Workplace Health, Safety and Compensation Commission of Newfoundland and Labrador, “VDT Workstation: Layout and Lighting”.
6. American Conference of Government Industrial Hygienists, (ISBN:1-882417-46-1); Physical Agents: Ergonomic, Lifting
7. Canadian Centre for Occupational Health and Safety. “Repetitive Motion Injuries (RMIs) Prevention Program” (Reprinted 2002), Hamilton, Ontario, Canada

APPENDIX A

SAMPLE RISK RECOGNITION CHECKLIST

RISK RECOGNITION CHECKLIST

Job Title: _____

Date: ___/___/___

Description of Work Location: _____

Task Description: _____

Evaluated by: _____

(Name)

(Title)

Health and Safety Committee Co-chairs or Worker Health and Safety Representative: _____

Worker(s) Names (Optional) _____

Names of others involved in the risk recognition process: _____

Following is a list of key risk factors. If “**yes**” is the answer to any of these questions, it means there is need for further evaluation of the risk factors as outlined in section 4 - Risk Evaluation. Generally, the more **yes** answers there are for any particular task or section of the checklist, then the higher the priority for **further risk evaluation** of that task.

MOVEMENTS, POSTURE AND LAYOUT DURING PHYSICAL WORK

			Comments
1.	Is there frequent or prolonged bending down to where the hands pass below mid-thigh height?	9 Yes 9 No	_____
2.	Is there frequent or prolonged reaching above the shoulder?	9 Yes 9 No	_____

Comments

- | | | | | |
|----|---|-------|------|-------|
| 3. | Is there frequent or prolonged bending due to extended reach forward? | 9 Yes | 9 No | _____ |
| 4. | Is there frequent or prolonged twisting of the back? | 9 Yes | 9 No | _____ |
| 5. | Are awkward postures used frequently or over prolonged periods; i.e., postures where a joint reaches its end range of motion. (See illustrations of awkward postures section 4.4.3, figure 3, in the Guidelines.) | 9 Yes | 9 No | _____ |
| 6. | Do pressure points occur during the performance of the task? | 9 Yes | 9 No | _____ |
| 7. | Is sitting or standing in one place required for prolonged periods without a rest period? | 9 Yes | 9 No | _____ |
| 8. | Is the task performed frequently or for long periods of time by the employee(s) without a rest period or change of task? | 9 Yes | 9 No | _____ |

MANUAL HANDLING

- | | | | | |
|-----|---|-------|------|-------|
| 9. | Are loads moved or carried over long distances? | 9 Yes | 9 No | _____ |
| 10. | Are weights handled: | 9 Yes | 9 No | _____ |
| | a. from a seated position, perceived to exceed individual capabilities? | | | |
| | b. in a position, other than a seated position, perceived to exceed individual capabilities? | 9 Yes | 9 No | _____ |
| | c. more than 32kg (70.5 lbs) or as per current edition of American Conference of Government Industrial Hygienists, Lifting TLVs | 9 Yes | 9 No | _____ |

Note: The weight noted here is not intended to be the maximum limit but is an important factor to be considered when evaluating and controlling risk.

Comments:

- | | | | | |
|-----|--|-------|------|-------|
| 11. | a) For pushing, pulling, carrying, holding or other applications of force, are large forces exerted or large weights used? | 9 Yes | 9 No | _____ |
| | b) Are there prolonged periods of applications of force? | 9 Yes | 9 No | _____ |
| 12. | Are the loads difficult or awkward to handle, for example, due to their size, shape, temperature, instability or unpredictability? | 9 Yes | 9 No | _____ |
| 13. | Is it difficult or unsafe to get adequate grip of the load? | 9 Yes | 9 No | _____ |

WORK ENVIRONMENT

- | | | | | |
|-----|---|-------|------|-------|
| 14. | Is the task performed in a restricted work space? | 9 Yes | 9 No | _____ |
| 15. | Is the lighting inadequate for safely performing the task? | 9 Yes | 9 No | _____ |
| 16. | Is the climate particularly cold or hot? | 9 Yes | 9 No | _____ |
| 17. | Are the floors cluttered, uneven, slippery or otherwise unsafe? | 9 Yes | 9 No | _____ |
| 18. | Is the working environment too noisy for the task? | 9 Yes | 9 No | _____ |
| 19. | Are workers exposed to vibration when using tools, machinery and/or equipment for the task? | 9 Yes | 9 No | _____ |

INDIVIDUAL FACTORS

- | | | | | |
|-----|--|-------|------|-------|
| 20. | Is the employee new to the work or returning from an extended period away from work? | 9 Yes | 9 No | _____ |
| 21. | Are there age-related factors, disabilities or other special factors that may affect task performance? | 9 Yes | 9 No | _____ |
| 22. | Does the employee's clothing or personal protective equipment interfere with task performance? | 9 Yes | 9 No | _____ |
| 23. | Are the skills and experience of the worker inadequate for the task? | 9 Yes | 9 No | _____ |

APPENDIX B

COMPLETED EXAMPLE RISK RECOGNITION CHECKLIST

COMPLETED EXAMPLE OF A RISK RECOGNITION CHECKLIST

Job Title: F ish Plant Production Line Worker Date: 06/19/02

Site Location: R andom B ite F ish Plant

Description of Work Environment: Moderately paced fillet line work in a well lit production area with loud equipment and machinery in immediate vicinity

Task Description: Stuffing fish fillets by placing ingredients on a fillet and rolling it into a ball shape using both hands

Evaluated by: Mr. Thomas Nolan Safety Representative
(Name) (Title)

Health and Safety Committee Co-chairs or Worker Health and Safety Representative:

~~Sid Stone (Management Co-Chair)~~ ~~Chuck Walsh (Worker Co-Chair)~~

Worker(s) Names (Optional)

F red Smith

Names of others involved in the risk recognition process:

H ans F ishmeister Line Supervisor

Following is a list of key risk factors. If “yes” is the answer to any of these questions, it means there is need for further evaluation of the risk factors as outlined in section 4 - Risk Evaluation. Generally, the more yes answers there are for any particular task or section of the checklist, then the higher the priority for **further risk evaluation** of that task.

**MOVEMENTS, POSTURE AND LAYOUT
DURING PHYSICAL WORK**

		Comments
1.	Is there frequent or prolonged bending down to where the hands pass below mid-thigh height?	9 Yes : No _____
2.	Is there frequent or prolonged reaching above the shoulder?	9 Yes : No _____
3.	Is there frequent or prolonged bending due to extended reach forward?	9 Yes : No _____
4.	Is there frequent or prolonged twisting	9 Yes : No _____

of the back?

- | | | | | |
|----|---|-------|------|----------------|
| 5. | Are awkward postures used frequently or over prolonged periods; i.e., postures where a joint reaches its end range of motion. (See illustrations of awkward postures section 4.4.3, figure 3, in the Guidelines.) | : Yes | 9 No | _____ |
| 6. | Do pressure points occur during the performance of the task? | 9 Yes | : No | _____
_____ |
| 7. | Is sitting or standing in one place required for prolonged periods without a rest period? | : Yes | 9 No | _____ |
| 8. | Is the task performed frequently or for long periods of time by the employee(s) without a rest period or change of task? | : Yes | 9 No | _____ |

MANUAL HANDLING

- | | | | | |
|-----|--|-------|------|-------|
| 9. | Are loads moved or carried over long distances? | 9 Yes | : No | _____ |
| 10. | Are weights handled: | 9 Yes | : No | _____ |
| 1. | from a seated position, perceived to exceed individual capabilities? | | | |
| 2. | in a position, other than a seated position, perceived to exceed individual capabilities? | 9 Yes | : No | _____ |
| 3. | more than 32kg (70.5 lbs) or as per current edition of American Conference of Government Industrial Hygienists, Lifting TLVs | 9 Yes | : No | _____ |

Note: The weight noted here is not intended to be the maximum limit but is an important factor to be considered when evaluating and controlling risk.

- | | | | | |
|-----|--|-------|------|-------|
| 11. | (a) For pushing, pulling, carrying, holding or other applications of force are large forces exerted or large weights used? | 9 Yes | : No | _____ |
| | (b) Are there prolonged periods of applications of force? | 9 Yes | : No | _____ |
| 12. | Are the loads difficult or awkward to handle, for example, due to their size, shape, temperature, instability or unpredictability? | 9 Yes | : No | _____ |
| 13. | Is it difficult or unsafe to get adequate grip of the load? | 9 Yes | : No | _____ |

WORK ENVIRONMENT

14. Is the task performed in a restricted work space? **9** Yes : No **T** here is adequate space for the task only
15. Is the lighting inadequate for safely performing the task? **9** Yes : No _____
16. Is the climate particularly cold or hot? : Yes **9** No Cold, to maintain fish quality
17. Are the floors cluttered, uneven, slippery or otherwise unsafe? : Yes **9** No Wet floors and inadequate grating
18. Is the working environment too noisy for the task? : Yes **9** No Difficult to hear normal conversation
19. Are workers exposed to vibration when using tools, machinery and/or equipment for the task? **9** Yes : No _____

INDIVIDUAL FACTORS

20. Is the employee new to the work or returning from an extended period away from work? : Yes **9** No Employee new to the assembly line
21. Are there age-related factors, disabilities or other special factors that may affect task performance? : Yes **9** No A rthritic symptoms in hands
22. Does the employee's clothing or personal protective equipment interfere with task performance? **9** Yes : No _____
23. Are the skills and experience of the worker inadequate for the task? : Yes **9** No N ew to assembly line, inexperienced in production

APPENDIX C

SAMPLE RISK EVALUATION CHECKLIST

RISK EVALUATION CHECKLIST

Job Title: _____

Task Description: _____

Date: _____

Health and Safety Committee Co-Chair _____
or Worker Health & Safety Representative _____

Worker (optional): _____

Evaluated by: _____

Following is a list of questions concerning the risk factors that need to be evaluated to determine whether the task is likely to cause soft tissue injury. If “yes” is the answer to any of these questions, it means there is an **increased risk of injury**. In the space provided indicate possible sources of risk and their suggested controls. Include the name of person(s) responsible for the control and the date for implementation. Use additional pages as required.

RISK FACTOR “A” - ACTIONS AND MOVEMENTS

			Source of Risk/Suggested Controls
Are actions or movements causing undue discomfort or pain?	9 Yes	9 No	_____
Are actions performed with sudden or jerking movement?	9 Yes	9 No	_____
Are tasks performed in an unbalanced and/or uncomfortable position?	9 Yes	9 No	_____
Does the task require a full range of joint movement which is prolonged or repetitive?	9 Yes	9 No	_____
Is there repetitive bending, twisting or over-reaching?	9 Yes	9 No	_____
Is a load shared unevenly between both hands, or lifted by one hand only?	9 Yes	9 No	_____
Is an object pushed or pulled across the front of the body?	9 Yes	9 No	_____

Source of Risk/Suggested Controls

Is there a need to bend over to one side to lift or move an object? 9 Yes 9 No _____

Are several tasks performed in one position where some might be better performed in a seated position and the others are best performed in a standing position? 9 Yes 9 No _____

RISK FACTOR “B” - WORKPLACE AND WORKSTATION LAYOUT

Is the layout **inappropriate** for the task and the physical dimensions of the employee(s) performing the task? 9 Yes 9 No _____

Is there **inadequate** space for movements involved in the task? 9 Yes 9 No _____

Are appropriate mechanical handling aids **not readily** available for the task? 9 Yes 9 No _____

Are the working heights **fixed or not matched** to the size of the employees and the tasks? 9 Yes 9 No _____

Is the space for moving legs and feet **inadequate or obstructed**? 9 Yes 9 No _____

Can the **order of tasks** be rearranged to reduce the number of movements performed by the employee? 9 Yes 9 No _____

RISK FACTOR “C” - WORKING POSTURES AND POSITION

Is the employee required to obtain an object which is difficult to reach or grasp? 9 Yes 9 No _____

During manual handling, is there frequent or prolonged:

- (i) above shoulder reaching? 9 Yes 9 No _____
- (ii) forward bending of the back? 9 Yes 9 No _____
- (iii) twisting of the back? 9 Yes 9 No _____
- (iv) sideways bending of the back? 9 Yes 9 No _____

RISK FACTOR “D” - DURATION, REPETITION AND FREQUENCY

Source of Risk/Suggested Controls

Are the same tasks being performed repeatedly or frequently throughout the duration of the work period? 9 Yes 9 No _____

Are small muscle groups overused by being held in the same position for long periods of time or prolonged repetitive movement? 9 Yes 9 No _____

RISK FACTOR “E” - LOCATION OF LOADS AND DISTANCES MOVED

Could distances over which loads are moved be shortened? 9 Yes 9 No _____

Are loads which are to be moved located above shoulder height or below mid-thigh height? 9 Yes 9 No _____

RISK FACTOR “F” - WEIGHTS AND FORCES

When lifting, moving, pulling or pushing an object, is the object difficult to move? 9 Yes 9 No _____

Is the employee required to exert a large force while seated? 9 Yes 9 No _____

Is the employee required to push/pull while seated without having good seating and solid foot support? 9 Yes 9 No _____

RISK FACTOR “G” - CHARACTERISTICS OF LOADS AND EQUIPMENT

Does the person or animal need to be moved in a special way? 9 Yes 9 No _____

Is the person or animal distressed, excited or moving vigorously? 9 Yes 9 No _____

Is the object awkward to carry? 9 Yes 9 No _____

Is the object difficult to grasp or hold? 9 Yes 9 No _____

Is the object unstable or unbalanced, or does it have contents that may move suddenly? 9 Yes 9 No _____

Is the object smooth, slippery, greasy or wet? 9 Yes 9 No _____

Source of Risk/Suggested Controls

Does the object have sharp edges or protrusions?	9 Yes	9 No	_____
Is the object very hot or cold?	9 Yes	9 No	_____
Does the object block the view of the employee when being handled?	9 Yes	9 No	_____

RISK FACTOR “H” - WORK ORGANIZATION

Is the work flow affected by delays, sudden changes or poor design in the flow of materials?	9 Yes	9 No	_____
Are there insufficient numbers of employees to carry out the work within a deadline?	9 Yes	9 No	_____
Are there insufficient numbers of employees to carry out the work during regular peak periods?	9 Yes	9 No	_____
Is there a lack of team lifting, and/or is it not safely organized when required?	9 Yes	9 No	_____
Is there a lack of an effective maintenance program for tools, buildings and equipment?	9 Yes	9 No	_____
Are procedures for reporting and fixing unsafe tools and equipment or environmental conditions inadequate ?	9 Yes	9 No	_____
Is the work flow intermittent and uneven?	9 Yes	9 No	_____
Is there a lack of effective purchasing, instruction and maintenance programs for tools and equipment?	9 Yes	9 No	_____

RISK FACTOR “T” - WORK ENVIRONMENT

Are the floors and surfaces underfoot uneven or slippery?	9 Yes	9 No	_____
Is the workplace untidy with a lack of attention to housekeeping details?	9 Yes	9 No	_____
Are there extremes of heat, cold, wind or humidity?	9 Yes	9 No	_____
Are there high levels of fumes, dusts, gases, steams, mists, or vapours?	9 Yes	9 No	_____

Source of Risk/Suggested Controls

Is there excessive vibration?	9 Yes	9 No	_____
Is there excessive noise?	9 Yes	9 No	_____
Is the task performed in a restricted space?	9 Yes	9 No	_____
Is there a problem with the level of lighting?	9 Yes	9 No	_____

RISK FACTOR “J” - SKILLS AND EXPERIENCE

Does the employee lack appropriate instruction in ergonomics risks or prevention techniques?	9 Yes	9 No	_____
Does the employee lack appropriate instruction in recognizing risk and evaluating tasks?	9 Yes	9 No	_____
Does the employee lack proper orientation for the job practices and safety requirements in the workplace?	9 Yes	9 No	_____
Does the employee lack the experience needed to perform the skill level required for the task?	9 Yes	9 No	_____
Does the physical demand of the task exceed the physical ability of the employee?	9 Yes	9 No	_____

RISK FACTOR “K” - AGE

Are any workers under the age of 18 years?	9 Yes	9 No	_____
Do young workers start a new job without receiving adequate information about safe work practices?	9 Yes	9 No	_____

RISK FACTOR “L” - WEARING APPAREL

Is special clothing required which may restrict movement?	9 Yes	9 No	_____
---	-------	------	-------

APPENDIX D

Definitions

DEFINITIONS

ACGIH	American Conference of Government Industrial Hygienists is a professional organization devoted to the administration and provision of technical information for occupational and environmental health.
Awkward Postures:	Where the posture or action required for the task creates some discomfort or is difficult to maintain, or takes place at the end range of motion for an anatomical joint.
Duration:	The amount of time over which a task is performed, or over which an employee is exposed to a hazardous risk.
End Range of Motion:	When an anatomical joint has reached either the smallest or largest possible angle of movement. (eg. the position of the shoulder joint when reaching overhead).
Ergonomics:	The applied science that seeks to fit the job to the worker through the evaluation and design of the work environment in relation to human characteristics, dimensions and interactions.
Essential Task:	A task which is deemed to be absolutely necessary in order to fulfill the purpose of the job.
Force:	The amount of physical energy which the body must exert in order to perform a particular action.
Frequency:	The rate of repetition of a task or action measured in time.
Hazard:	A condition or practice with the potential to cause harm, loss or injury.
Incidence Rate:	The rate at which injuries and illnesses occur for a given job, production line, work area, department or company.
Injury Frequency Rate:	Incidence rate of lost workday cases: $\frac{\text{Number of recordable cases} \times 200,000}{\text{Exposure or employee-hours}}$
Injury Severity Rate:	Incidence rate of lost workdays: $\frac{\text{Number of lost workdays} \times 200,000}{\text{Exposure or employee-hours}}$
Instruction:	Imparting practical knowledge or information on a particular subject
Local Contract Stress:	(See Pressure Points)

Manual Handling:	An activity wherein a person is required to exert force to lift, lower, push, pull, carry or otherwise move, hold or restrain any animate or inanimate object.
Posture:	The position of different parts of the body.
Pressure Points or Local Contact Stress:	Occurs when a hard or sharp object comes in contact with the skin. Nerves and tissues beneath the skin can become injured by the pressure.
Repetition:	Involves doing a task that uses the same muscles over and over with little chance for rest or recovery. This applies to both large-muscle groups (eg. the back) and small-muscle groups (eg. hands/wrists).
Risk:	Probability during a period of activity that a hazard will result in an accident with definable consequences.
Risk Control:	Eliminating or minimizing the risks recognized or identified in a job or task. It is changing the job, workstation, tools or environment to fit the worker.
Risk Evaluation:	Involves assessing the possibility of injury or harm occurring to a person if exposed to a risk.
Risk Recognition:	Recognizing things which may cause injury or harm to the health and/or safety of a person.
Soft Tissue Injury:	An injury or disorder of the muscles, tendons, ligaments, joints, nerves, blood vessels or related soft tissue including a sprain, strain and inflammation, that may be caused by aggravated muscles.
Sprain:	Over-stretching or over-extension of a ligament that results in a tear or rupture of the ligament.
Strain:	Over-stretching or overextension of a muscle or tendon.
Static Posture:	A position or posture which is held for a long time.

APPENDIX E
CASE STUDIES

Appendix E

Case Studies

The case studies in this Appendix show how risk recognition, risk evaluation and risk control can be applied to physical tasks in a range of industries.

CASE STUDY 1 - HEALTH CARE INDUSTRY

Handling of non-ambulatory residents in a nursing home for the elderly

Risk Recognition

At a meeting of the nursing home's health and safety committee, a member raises the issue of manual handling. The member is particularly concerned about tasks that involve the handling of non-ambulatory residents.

The committee agrees that these tasks involve risks of soft tissue injury (STI) because they require:

- repetitive or sustained application of force
- repetitive or sustained awkward postures
- repetitive or sustained movements
- application of high force
- handling of live people.

As risks have already been recognized, there is no need to complete a Risk Recognition Checklist. As no risk evaluation of these handling tasks has been done before, the committee agrees to do it.

Risk Evaluation

A risk evaluation team is formed comprising an employer representative (a nurse supervisor) and two health and safety committee members (a nurse and a nursing aid). The team gets together at various times over the next two weeks and observes a range of resident handling tasks, following the guidance in the risk evaluation section of the Guidelines.

Although they don't examine every handling situation that can take place, they use their knowledge and experience to ensure they cover the full range of handling tasks that are done in the nursing home. The handling tasks they examine include:

- bathing and toileting
- turning residents in bed
- dressing and undressing

- assisting residents to sit up and lie down in bed
- transferring residents from the bed to a chair or wheelchair and back again.

In order to have a record of their evaluation, they complete the Risk Evaluation Checklist for each handling task they examine.

Using the checklist, the team finds a number of repetitive and sustained postures, movements and forces present in the tasks. How often these occur and for how long they are sustained varies considerably between different tasks and different employees.

They also determine that high force is common to most tasks. This means that there are STI risks involved in most tasks and risk control is required. For tasks involving high forces, the risk of a staff member incurring STI will increase as the number of tasks they are required to do increases.

On each Risk Evaluation Checklist, the team also comments on possible sources of risk. These include:

- the weight of the resident
- the resident's ability to cooperate with staff during a handling task
- the availability of mechanical aids (some areas don't have aids at all, some aids are not used because they don't work very well, and some aids are kept well away from where handling occurs; thus staff find it inefficient to get the aid and return it later because of time pressures)
- the layout and set-up of some of the rooms (some bathrooms are too small to use aids in, and some doorways into residents' rooms are too small for the aid to pass through)
- the fact that the nursing home employs a lot of casual agency staff (who may be unaware of existing resident handling procedures, may not know how to use lifting aids and may not be aware of some resident care plans; thus are not aware of what level of cooperation they can expect from a resident during a handling task)

Risk Control

Using the Checklist comments, the team identifies the risk factors.

- the inherent nature of the task

- the layout of the work area sometimes forces staff into awkward postures
- the different sizes, shapes, weights and conditions of the residents
- poor wheelchair design - the sides can't be removed or the resident needs to be lifted over the wheel
- the height of some beds can't be adjusted
- the different sizes and physical strengths of staff members
- the time taken to carry out the transfer can depend on the skills of staff members
- the different lifting techniques that are used
- time pressures on staff prevent proper set-up for the lift, such as adjusting the bed height or getting extra assistance
- poor work organization and inadequate staffing levels increase the number of transfers each staff member has to do in a shift, and restrict the number of staff available to perform a transfer

Risk controls should reduce or eliminate the risk factors. Keeping this in mind, the team then develops the following risk control options:

Modify Workplace Layout

- ensure clear access around the bed for staff members and wheelchairs

Administrative Controls

- ensure that enough staff are available for transfers
- change the transfer to a sliding transfer rather than a lift
- institute a "no lift" program
- use the patient assessment process for mobility and display the lift and transfer logos properly

Tool design and modification

- use wheelchairs with removable sides, and with wheels and a back that do not obstruct the lift; make sure the wheelchair can be easily and securely braked during the transfer
- make sure the height of the beds is easily adjustable

Provide mechanical handling aids

- make sure a patient lift or other suitable aid is used for transfers

Provide instruction in manual handling techniques

- provide additional instruction on appropriate handling techniques and the use of lift and transfer logos

The team reports back to the health and safety committee, who then considers the practicability of the options, and decides what controls will be implemented and when. The committee refers to the Control Factors (in Section 5) of the Guidelines and their suggested controls in the Risk Evaluation Checklist.

CASE STUDY 2 - CONSTRUCTION INDUSTRY

Using a jackhammer to break up pavement

Risk Recognition

Joe uses a jackhammer to break up pavement, working for around 8 hours each day.

Using the Risk Recognition Checklist, the supervisor and health and safety representative agree that the task involves risk of STI because Joe:

- is exposed to sustained vibration
- repeatedly uses sustained force to operate the jackhammer
- applies high force to reposition the jackhammer when it becomes stuck, and to lift the jackhammer onto and off the truck
- handles an unbalanced load, because the weight of the jackhammer is unevenly distributed

Risk Evaluation

Joe's supervisor and health and safety rep have a closer look at the task, following the guidance in the Risk Evaluation Checklist of the Guidelines. They find the following risk factors and record them on the Risk Evaluation Checklist.

Repetitive or sustained postures, movements and forces

- bending the back forward towards the end range of motion
- bending the head forward near the end range of motion
- bending the wrist when operating the jackhammer
- supporting the tool while it is hammering
- exerting force while in an awkward posture

Long duration

- the task is done for up to 5 minutes at a time with short breaks for a minute or two - this work cycle can continue for 20 or 30 minutes at a time
- the total time Joe spends jackhammering is about two and a half hours a day

High force

- lifting, lowering and carrying a heavy load (when lifting the jackhammer onto and off the truck, and when carrying it and repositioning it)

- applying uneven, fast or jerky forces during lifting, carrying, pushing or pulling.
- applying unexpected forces when the jackhammer breaks through concrete
- supporting a heavy object
- exerting high force while in an awkward posture (the jackhammer is heavy, and needs to be lifted off the truck at arm's length)

Joe tells his supervisor that he experiences some pain when jackhammering, that he can only do the job for short periods at a time, and that he sometimes gets another employee to help him lift the jackhammer onto the truck.

Work environment

- Joe is subjected to prolonged hand-arm vibration
- because the task is done outdoors, Joe is sometimes exposed to hot, humid, wet or cold conditions
- Joe needs to wear heavy protective clothing while working in hot or cold conditions

Risk Control

Using the risk control sections of the Guidelines (Section 5), the supervisor and health and safety rep decide what features of the task are the sources of risk (section 5.1.6 of Guidelines).

- features of the tool (including vibration, and its heavy and unbalanced weight)
- the task is performed outdoors in all weather
- the truck is often parked a fair way from where the jackhammering is done, so Joe needs to carry the tool to the work area
- because of the way the work is organized, one employee does the job for prolonged periods
- the height of the jackhammer is determined by the length of the chisel attached, and this is not changed according to the user's height - this results in some users adopting awkward postures
- the jackhammer is not serviced regularly, nor is the chisel sharpened

Risk controls were considered for practicability.

Severity of risk

Joe risks incurring a STI, in the back, hands, arms or shoulders. The severity and cost of these types of injuries can be significant.

There is also the risk of a vibration-induced STI, which increases with the duration of the task and when working in cold, wet conditions.

Best practice

The employer contacted several companies that use jackhammers. One reported that they had recently bought a new model of jackhammer, which was lighter and had improved damping mechanisms. This had reduced the risks of both lifting and using the tool.

They had also restricted the amount of time that individual employees spent doing the work on any given day, to further reduce the risk. In addition, they had instructed their employees in team lifting the equipment onto and off the truck.

Another company had used backhoes with a pavement-breaker attachment wherever access allowed. They had also modified the backhoe with suitable vibration damping to minimize the operator's exposure to whole-body vibration.

Availability and suitability of suggested risk controls

Service of the existing jackhammer can be arranged immediately. The supplier confirms that they could supply the new model and extra chisels within a few days.

The rotation of workers on the task can be arranged immediately. This will reduce Joe's exposure to vibration and unexpected forces. Team lifting will also reduce the handling risk.

Use of a backhoe with a pavement-breaker attachment should not create further risk by exposing the operator to vibration and other risk factors. This solution will not be useful where access is a problem.

A cradle for the jackhammer can be manufactured in the workshop and attached to the truck's tailgate in an easily accessible position. This will reduce the risk of lifting the heavy tool at arm's length off the truck.

Cost

- a new jackhammer costs about \$2,000 and extra chisels cost \$50 each
- there is minimal cost involved in making the cradle, since it can be done in the company's workshop
- changes to work procedures will cost nothing, but instructing other workers in how to handle and use the jackhammer will take several hours
- servicing the existing and new jackhammer is a routine task that should take place anyway and will not involve any additional cost

- the use of the backhoe needs to be assessed to ensure that it does not introduce other risks, and this will require staff time; the pavement-breaker attachment would need to be leased as required and attached to the backhoe.

The following risk controls were set in place:

- reduce the distance that the jackhammer needs to be carried by parking the truck as close as possible to the work area
- provide adequate job rotation to reduce each worker's exposure to the task
- order the new jackhammer and chisels; show workers how to select chisels that are suitable for their height and the job
- design, fabricate and mount a cradle on the truck for holding the jackhammer
- develop a maintenance schedule for the existing jackhammer and new jackhammer in line with the manufacturer's specifications
- provide appropriate gloves for the job
- organize instruction on the risks associated with the task and appropriate handling techniques

CASE STUDY 3 - RETAIL INDUSTRY

Restocking shelves in a supermarket

A supermarket chain initiates a program to prevent STI. Each supermarket forms a two-person team (store manager and health and safety rep) to recognize and evaluate risks associated with restocking supermarket shelves to develop and implement any necessary risk controls.

The shelves are set up as follows:

- the shelving is about 2 metres high and contains 5 or more shelves, depending on the type and size of product
- freezers are similar, but do not have shelves close to the floor level
- dairy coolers do not have the lowest shelves, but are deep, and employees must lean over the wide lower section to reach the back of the shelves
- boxes of stock are placed on the floor, or on another box, in front of the shelf that employees are stocking

Employees have complained, particularly about the heavier products such as large bottles of detergent, juice and soft drink and large bags of dog food, and about stocking high shelves. There is a high turnover of staff in the stocking team.

Risk Recognition

Because of the employees' concerns, the store manager and health and safety rep examine the task and decide it involves the following risks for soft tissue injury:

- repetitive application of force (to lift stock and place it onto the shelves)
- repetitive awkward posture (bending down sideways to pick up stock from the boxes, and lifting the arms and raising the shoulders to stock higher shelves)
- sustained awkward posture (bending the neck, head and back when stocking the lower shelves)
- application of high force (when handling heavy objects with one hand, including large cans and bottles)

Risk Evaluation

The store manager and health and safety rep evaluated the task using the Guidelines and Risk Evaluation Checklist. The following risk factors were identified.

Actions, movements, posture and position

- bending the back forwards or sideways towards end range of motion
- twisting the back
- bending the head forwards or sideways and twisting the neck
- leaning backwards and reaching upwards when stocking the upper shelves
- reaching forwards using back and arms (when placing items on shelves, particularly the low and high shelves and the dairy coolers)
- working with both hands above shoulder height when stocking higher shelves
- squatting or kneeling to stock the lower shelves
- bending the wrist when taking items from boxes and when placing them on the high and low shelves
- grabbing actions with the fingers and hands
- working and gripping with the fingers wide apart for large items
- very fast movements at peak times

Duration, Repetition and Frequency

- most restocking is done at night, but some restocking of the dairy coolers and freezers occurs during the day.
- employees stock shelves for more than 2 hours over the night shift, and for more than 30 minutes at a time during the day.
- repetitive lifting, lowering and grasping occurs throughout this task.

Weights and Forces

- lifting and lowering heavy loads (when stocking heavy items such as bottles of drink and detergent, large packets of sugar and flour, large cans of fruit and bags of dog food, and gardening products)
- exerting force at the limit of the grip span (using an openhanded grip to pick up large items with one hand)
- exerting force with the non-dominant hand
- throwing half-filled boxes up to employees standing on a ladder to store on top of shelves
- exerting force while in an awkward posture (lifting and placing stock when crouched down or when reaching upwards)

Employees have reported:

- pain and discomfort in wrists, arms, shoulders, back and knees during and after stocking
- that stocking of high shelves can only be done for short periods at a time

The team agrees that the task poses a risk because it involves:

- repetitive and awkward postures, movements and high forces, and long duration

Work environment

- restocking the dairy cooler and freezer involves working in a cold or very cold environment
- restocking the freezer requires handling very cold objects

Because restocking the freezers and dairy coolers is done in a cold environment, this increases the risk associated with these tasks.

Risk Control

Using the Risk Control Section of the Guidelines and their completed Risk Evaluation Checklist, the store manager and health and safety rep decide what features of the task are the sources of risk:

- the work has to be done within a set time, leading to fast, repetitive actions, movements and forces
- rotating the stock on the shelves requires twisting and reaching
- because they don't have a stool to sit on, employees have to kneel or crouch to reach the lowest shelves
- there aren't enough step stools to go around, so some employees can't reach the high shelves comfortably
- all boxes are placed on the floor, and the few trolleys available are used for distributing boxes, as opposed to platforms from which to stock
- due to the way the work is organized, employees who stock shelves do it for long periods, and don't do any other tasks during that time
- employees who restock the dairy cooler and freezers don't wear any protective clothing to prevent the effects of working in a cold environment

The store manager and health and safety rep discussed various options for risk control, including:

- ensuring that enough employees are scheduled for each shift to reduce the frequency of postures, movements and forces
- stocking shelves with items left in their cartons with the front removed - this would eliminate the need to stock items individually and reduce bending, gripping, reaching and twisting (as long as handling these cartons would not require the application of high force)
- ensuring that boxes of stock for the higher shelves are placed on trolleys to minimize repetitive bending
- providing adjustable height trolleys or portable roller conveyors to lift the height of the boxes to the appropriate level
- providing portable steps to raise the employees closer to the high shelves
- providing low steps or stools for employees to sit on while stocking the lowest shelves
- rotating staff to other tasks such as clearing cardboard, and breaking down pallets onto trolleys, to reduce the length of time spent stocking shelves
- providing suitable warm clothing for freezer and dairy work

Longer term solutions discussed included:

- designing the dairy coolers differently, so that employees and customers wouldn't have to reach as far to the shelves
- reducing the height of shelves where possible, particularly for popular or heavier items (this is also better for customers who find it difficult to reach the high shelves)

Risk controls were considered for practicability.

Severity of the risk

- employees who stock shelves risk developing STI, in the back, neck, hands, arms or shoulders
- the cost and severity of these types of injuries can be significant
- there are a number of employees in the store whose only work is stocking shelves
- employees have reported some symptoms and difficulties in carrying out the tasks, indicating that the risk is high

Best practice

Discussing the task with other store managers, the team found that most stores had STI claims and reports of pain associated with shelf stocking. Some employees with back and shoulder problems took a long time to get back to their usual duties.

Throughout the industry, low wide steps and higher mobile steps with standing platforms are used to access high shelves. The team found that a number of other stores had provided enough sets of steps to allow all employees to fill high shelves at a comfortable height. The employees sat on the steps to fill low shelves without having to kneel or crouch.

Some stores had also used flat, waist-high trolleys and shopping trolleys modified with a working shelf to place boxes within easy reach, to minimize bending.

Several stores introduced other tasks to break up the time spent stocking including breaking up empty boxes and cleaning shelves and dairy coolers. They also moved employees between aisles so that the time spent lifting large, heavy items was reduced or broken up with time lifting smaller, lighter items.

In addition, they found that instructing employees in manual handling techniques improved the employees' movements during stocking.

Availability and suitability of suggested risk controls

Most solutions would be readily available, suitable for the workplace and easy to put in place:

- changes to staffing numbers and the way the tasks are done could be made within a few days
- extra steps and stools could be easily obtained from the store's current suppliers
- gloves and other protective clothing for working in cold conditions are readily available from safety suppliers
- a local carpenter can manufacture wooden shelves to fit on trolleys within a few days
- instructing employees in manual handling techniques could be arranged through experienced personnel.

Cost

Changes in the way the work is organized will cost little, apart from the time required to brief the team at the beginning of the shift.

Employing more staff will cost the usual rate, but the stocking shift may finish faster.

The low steps are plastic and cost about \$150 each. The mobile steps are made of steel, range in size and price from three-step (\$600) to four or more steps with a top platform (several thousand dollars).

There was also the cost of instructing employees in manual handling techniques.

The following risk controls were set in place:

- the workplace was altered by providing more sets of mobile steps and low steps
- shelves for shopping trolleys were made and provided for shelf stockers; employees distributing boxes were told to place all stock for shelves of waist height and above on these trolleys
- employees restocking the dairy coolers and freezers were given appropriate protective clothing
- the store trialed an adjustable height trolley for the boxes, with a view to purchasing some in the future
- the store manager asked head office to review future dairy coolers and shelving **design, as well as stock location**, in light of the risk evaluation.

CASE STUDY 4 - OFFICE ENVIRONMENT

Performing word processing tasks

In an office environment, computers are used by staff on an ongoing basis to process forms, type documents (word processing), conduct Web research and other administrative tasks. In this business, four employees have formed an ergonomics focus group, since ergonomics is a major issue at this workplace. One of the four people is the health and safety representative.

At a meeting of the ergonomics focus group, the supervisor raised concerns about the amount of absenteeism and the associated lost productivity.

The worker health and safety representative commented that employees had reported pain and discomfort when performing word processing tasks and that most of the time one or two employees were in receipt of medical attention (e.g. physiotherapy, massage therapy, etc.) for their work related discomfort.

Risk Recognition

The supervisor and health and safety representative examined the word processing task and found that it involved the following ergonomics risks and the sources of these risks:

- all of the cubicles were configured in the same way despite the different types of equipment, different sizes and shapes of employees and the slightly different work tasks undertaken by each of them, causing awkward postures for extended periods of time
- the adjustable features of the chairs were not demonstrated to the workers; therefore many were sitting in an inappropriate posture
- the mouse is on the desk surface as opposed to being on the keyboard tray surface, since the trays are just large enough for the keyboard only. Workers therefore use incorrect shoulder and arm postures for long periods of time
- every week the workload increases significantly on one day, requiring faster pace and longer hours at their workstation to get the work done. This is due to the way work is organized between departments of the company
- workers were not placing items within easy reach (primary work zone) and were therefore overreaching to retrieve frequently used items

- workers using the telephone were noted to be positioning the receiver between the ear and the shoulder, while simultaneously keyboarding, causing prolonged flexing of the neck
- workers typically turn their heads and look down at the documents on the desk surface rather than using document holders in order to avoid the prolonged awkward posture
- some workers use a keyboard tray which is too low, or too high, therefore the wrists are bent (flexed or extended) for prolonged periods
- some employees had inadequate knowledge of ergonomics risk recognition, evaluation and control

The supervisor and health and safety representative agreed that because the task involved ergonomics risks, it was necessary to do a risk evaluation.

Risk Evaluation

Using the Risk Evaluation section of the Guidelines, they completed the Risk Evaluation Checklist. The following risk factors were noted:

Actions and Movements

- parts of the task performed in an uncomfortable position
- prolonged or repetitive full range of joint movement
- repetitive bending, twisting and over-reaching

Workplace and Workstation Layout

- inappropriate layout for the task and/or the physical dimensions of the employee(s)
- inadequate space for appropriate computer mouse operation
- working heights not matched to the size of the employees and the tasks they perform.

Working Postures and Position

- employees retrieve objects which are difficult to reach

Duration, Repetition and Frequency

- same tasks are being performed repeatedly and/or frequently throughout the duration of the work period causing overuse of small muscle groups (i.e. keyboarding)

Work Organization

- there are insufficient numbers of employees to carry out the work during regular peak periods
- intermittent and uneven work flow
- lack of effective instruction when new equipment is purchased (e.g. chair adjustments)

Skills and Experience

- lack of appropriate instruction in ergonomics risk recognition, evaluation and prevention (controls)
- lack of proper orientation to the job practices

The supervisor and the health and safety representative agree that the task and the set up should be modified due to high absenteeism, reduced productivity, and complaints received from employees.

Risk Control

Referring to the risk controls outlined in the Guidelines, the ergonomics focus group discussed the problem and brain-stormed possible solutions. The task could not be eliminated, therefore the group looked for possible solutions from employees performing the task.

One employee suggested that a representative from a local office furniture supplier be asked to deliver an in-service on the adjustable features of the chairs. This would provide workers with the knowledge and skill needed to make appropriate adjustments. In addition, the representative could discuss options available to the company for purchasing appropriate furniture for the task (e.g. cubicles, desks, etc.). Since this is a major capital investment, this would be considered to be part of a long term plan for changes in workstation design and would need to be budgeted appropriately. Management decided that new workstations would be purchased over time in order of high risk priority.

Another employee suggested that the work flow from other departments be analyzed in terms of how and when it arrives for processing, so that the workload can be balanced throughout the week.

An employee with neck problems stated that the use of headsets and document holders would be helpful. After discussions with management, the team decided that the headsets would be provided for employees who must use the computer or take notes while using the telephone. Document holders would be provided for all employees who refer to documents when word processing.

The ergonomics focus group suggested that they receive training in basic ergonomics principles from a local provider. This would enable them to better understand what immediate, simple changes could be made to the current set up of the workstations. Also, they would learn about stretching programs and regular rest breaks to avoid repetitive overuse of muscle groups. The management has agreed that once the group has received the training, options would be

considered whether to have the group or an outside consultant provide in-house instruction for all employees.

The management expressed an interest in rotating employees among tasks which would provide rest breaks for the small muscle groups being used in the keyboarding tasks. Since this can be a difficult process, they agreed to work together with the ergonomics focus group and a selected group of employees to try a job rotation procedure for a period of time. Following that time, there will be an evaluation to see how effective the job rotation has been.